



HERCULES

BETRIEBSANLEITUNG | MODE D'EMPLOI
GEBRUIKSHANDLEIDING | OPERATING INSTRUCTIONS
MANUAL DE INSTRUCCIONES | ISTRUZIONI PER L'USO

Bicycle

Contents

1	About these operating instructions	4	5	Assembly	23
1.1	Manufacturer	4	5.1	Required tools	23
1.2	Type number and model	4	5.2	Unpacking	23
1.3	Laws, standards and directives	4	5.2.1	Scope of delivery	23
1.4	For your information	5	5.3	Commissioning	23
1.4.1	Warnings	5	5.3.1	Installing the wheel in the Suntour fork	24
1.4.2	Markups	5	5.3.1.1	Screw-on axle (15 mm)	24
2	Safety	6	5.3.1.2	Screw-on axle (20 mm)	25
2.1	General warnings	6	5.3.1.3	Quick release axle	25
2.1.1	Toxic substances	6	5.3.1.4	Quick release	29
2.1.1.1	Brake fluid	6	5.3.2	Installing the wheel in the FOX fork	30
2.2	Requirements for the rider	7	5.3.2.1	Quick release (15 mm)	30
2.3	Vulnerable groups	7	5.3.2.2	Kabolt axle	32
2.4	Personal protective equipment	7	5.3.3	Checking the stem and handlebars	32
2.5	Safety markings and safety instructions	7	5.3.3.1	Checking connections	32
2.6	Emergency	7	5.3.3.2	Firm hold	33
2.6.1	What to do in an emergency	7	5.3.3.3	Checking the headset backlash	33
2.6.2	Leaking fluids	7	5.4	Selling bicycles	33
2.6.2.1	Brake fluid	7	6	Operation	34
2.6.2.2	Oils and lubricants from the fork	7	6.1	Risks and hazards	34
2.6.2.3	Oils and lubricants from the rear frame damper	7	6.1.1	Personal protective equipment	34
3	Overview	8	6.2	Instruction and customer service	35
3.1	Description	9	6.3	Adjusting the bicycle	35
3.1.1	Wheel	9	6.3.1	Adjusting the saddle	35
3.1.1.1	Valve	9	6.3.1.1	Adjusting the saddle tilt	35
3.1.2	Suspension	9	6.3.1.2	Determining the seat height	35
3.1.2.1	Rigid fork	9	6.3.1.3	Adjusting the seat height with quick release	37
3.1.2.2	Suspension fork	9	6.3.1.4	Height-adjustable seat post	37
3.1.2.3	Steel suspension fork	10	6.3.1.5	Adjusting the seat position	39
3.1.2.4	Air suspension fork	11	6.3.2	Adjusting the handlebars	40
3.1.2.5	Suntour rear frame damper	12	6.3.3	Adjusting the stem	40
3.1.2.6	FOX rear frame damper	13	6.3.3.1	Adjusting the height of the handlebars	40
3.1.3	Brake system	13	6.3.3.2	Adjusting the quick release clamping force	40
3.1.3.1	Rim brake	13	6.3.4	Setting the brake	41
3.1.3.2	Disc brake	14	6.3.4.1	Setting the grip distance on a Magura HS33 brake lever	42
3.1.3.3	Back-pedal brake	15	6.3.4.2	Setting the grip distance on a Magura HS22 brake lever	43
3.2	Proper use	16	6.3.4.3	Setting the grip distance on a Magura disc brake lever	43
3.3	Improper use	17	6.3.4.4	Setting the pressure point on a Magura brake lever	45
3.4	Technical data	18	6.3.5	Retracting the brake linings	46
3.4.1	Bicycle	18	6.3.6	Adjusting the Suntour fork	46
3.4.2	Tightening torque	18	6.3.6.1	Adjusting the negative deflection	46
3.5	Environmental requirements	19	6.3.6.2	Adjusting the steel suspension fork negative deflection	46
3.6	Description of controls and screens	21	6.3.6.3	Adjusting the air suspension fork negative deflection	47
3.6.1	Handlebars	21			
4	Transporting and storing	22			
4.1	Physical transport characteristics	22			
4.1.1	Dimensions during transportation	22			
4.1.2	Transport weight	22			
4.1.3	Designated handles/lifting points	22			
4.2	Transporting	22			
4.3	Storing	22			

6.3.6.4	Adjusting the air suspension fork rebound	48	7.4.1.1	Checking the tyres	77
6.3.7	Adjusting the FOX fork	48	7.4.1.2	Checking the rims	77
6.3.7.1	Adjusting the negative deflection	49	7.4.1.3	Checking and adjusting the tyre pressure – Dunlop valve	77
6.3.7.2	Adjusting the rebound	50	7.4.1.4	Checking and adjusting the tyre pressure – presta valve	77
6.3.8	Setting the Suntour rear frame damper	51	7.4.1.5	Checking and adjusting the tyre pressure – Schrader valve	77
6.3.8.1	Adjusting the negative deflection	51	7.4.2	Brake system	78
6.3.8.2	Adjusting the rebound	51	7.4.3	Checking the brake linings for wear	78
6.3.8.3	Setting the compression	52	7.4.4	Checking the pressure point	78
6.3.9	Setting the FOX rear frame damper	52	7.4.5	Checking the brake discs for wear	78
6.3.9.1	Adjusting the negative deflection	52	7.4.6	Electrical cables and brake cables	78
6.3.9.2	Adjusting the rebound	53	7.4.7	Gear shift	78
6.4	Accessories	55	7.4.8	Stem	78
6.4.1	Child seat	55	7.4.9	Checking the belt and chain tension	79
6.4.2	Bicycle trailer	56	8	Maintenance	81
6.4.3	Pannier rack	56	8.1	Axle with quick release	82
6.5	Before each ride	57	8.1.1	Checking the quick release	82
6.6	Check list before each ride	57	8.2	Adjusting the gear shift	83
6.7	Before each ride	58	8.2.1	Cable-operated gear shift, single-cable	83
6.8	Check list before each ride	58	8.2.2	Cable-operated gear shift, dual-cable	83
6.9	Using the kickstand	59	8.2.3	Cable-operated twist grip, dual-cable	84
6.9.1	Raising the kickstand	59	9	Troubleshooting, fault clearance and repair	85
6.9.1.1	Parking the bicycle	59	9.1	Repair	85
6.10	Using the pannier rack	59	9.1.1	Original parts and lubricants	85
6.11	Brake	61	9.1.2	Replacing the lighting	85
6.11.1	Using the brake lever	62	9.1.3	Adjusting the headlight	85
6.11.2	Using the back-pedal brake	62	9.1.4	Tyre clearance check	85
6.12	Suspension and damping	62	10	Recycling and disposal	86
6.13	Gear shift	69	10.1	Assembly report	87
7	Cleaning and servicing	73	10.2	Maintenance instructions	89
7.1	Cleaning after each ride	73	11	Glossary	91
7.1.1	Cleaning the suspension fork	73	12	Keyword index	94
7.1.2	Cleaning the rear frame damper	73			
7.1.3	Cleaning the pedals	73			
7.2	Basic cleaning	74			
7.2.1	Cleaning the frame	74			
7.2.2	Cleaning the stem	74			
7.2.3	Cleaning the wheel	74			
7.2.4	Cleaning the drive elements	74			
7.2.5	Cleaning the rear frame damper	74			
7.2.6	Cleaning the chain	75			
7.2.7	Cleaning the brake	75			
7.3	Servicing	75			
7.3.1	Servicing the frame	75			
7.3.2	Servicing the stem	76			
7.3.3	Servicing the fork	76			
7.3.4	Servicing the drive elements	76			
7.3.5	Servicing the pedals	76			
7.3.6	Servicing the chain	76			
7.3.7	Servicing the drive elements	76			
7.4	Maintenance	76			
7.4.1	Wheel	76			

1 About these operating instructions

Thank you for your trust!

HERCULES *bicycles* are premium quality bicycles. You have made an excellent choice. Your specialist dealer will provide you with guidance and instruction and assemble your product. Your specialist dealer will also be happy to assist you in the future whether you require maintenance, conversion or repair.

Notice

These *operating instructions* are not a substitute for personal instruction by the supplying specialist dealer.

These operating instructions form an integral part of the bicycles. Therefore, if it is re-sold at a later time, they must be handed over to the subsequent owner.

You are receiving these operating instructions with your new bicycle. Please take time to become familiar with your new bicycle and follow the tips and suggestions in the operating instructions. They will help you to enjoy your bicycle for a long time to come. We hope you have fun and wish you well on all of your rides!

These operating instructions are mainly designed for the rider or the operator. They aim to ensure that non-professionals can use the bicycle safely.



Sections are also designed especially for the specialist dealer. These sections aim to ensure that specialist dealers complete initial assembly and maintenance safely and reliably. The sections for specialist dealers are highlighted in grey and marked with a spanner symbol.

Download the operating instructions onto your phone at the following link, so that you can use them when you are out riding:



<https://www.hercules-bikes.de/de/de/index/downloads.html>

1.1 Manufacturer

The manufacturer of the bicycles is:

HERCULES GMBH
Longericher Straße 2
50739 Köln, Germany

Tel.: +49 4471 18735 0
Fax: +49 4471 18735 29
E-mail: info@hercules-bikes.de
Website: www.hercules-bikes.de

1.2 Type number and model

You will find identification number at the bottom left-hand side of each page. The identification number is composed of the document number, the version number and the release date.

Identification number	MY20H09-2 - 1_1.0_13.01.2020
-----------------------	------------------------------

1.3 Laws, standards and directives

The *operating instructions* comply with the essential requirements specified in:

- ISO 4210-1: 2015-01 – Cycles – Safety requirements for bicycles
- EN 11243:2016, Cycles – Luggage carriers for bicycles – Requirements and test methods
- IEC/IEEE 82079-1:2019-05 – International Standard for Preparation of information for use (instructions for use) of products
- ISO 17100:2016-05 Translation Services – Requirements for translation services.

1.4 For your information

Different markings are used in the operating instructions to make them easier to read.

1.4.1 Warnings

Warnings indicate hazardous situations and actions. You will find warnings in the *operating instructions*:



Will lead to serious or even fatal injuries if ignored. High-risk hazard.



May lead to serious or even fatal injuries if ignored. Medium-risk hazard.



May lead to minor or moderate injuries if ignored. Low-risk hazard.



May lead to material damage if ignored.

1.4.2 Markups

You will find stylised forms of typeface *in the operating instructions*:

Stylised form	Use
<i>Italics</i>	Glossary term
<u>Underlined in blue</u>	Link
<u>Underlined in grey</u>	Cross references
✓ Check marks	Requirements
▶ Triangle	Instruction for action
1 Instruction for action	Several instructions for action in specified order
⇒	Result of the action
SPACED	Indicators on the display screen
•	Bulleted lists
<u>Only applies to bicycles with this equipment</u>	Each type has a different kind of equipment. A note beneath the heading indicates components which can be used as an alternative.

Table 1: Markups

Instructions for specialist dealers are highlighted in grey. They are indicated by a screwdriver symbol. Information for specialist dealers does not require non-professionals to take any action.



2 Safety

2.1 General warnings

2.1.1 Toxic substances

2.1.1.1 Brake fluid

**DANGER****Death due to intoxication**

Brake fluid may leak out after an accident or due to material fatigue. Brake fluid can be fatal if swallowed or inhaled.

First aid treatment

- ▶ Remove those affected from the danger area to fresh air.
- ▶ Never leave those affected unattended.
- ▶ Immediately remove any clothing items contaminated with brake fluid.
- ▶ Never inhale vapours or aerosols. Ensure sufficient ventilation.
- ▶ Wear gloves and safety glasses as protective equipment.
- ▶ Keep unprotected persons away.
- ▶ Take care with leaked brake fluid as it poses a slip hazard.
- ▶ Keep leaked brake fluid away from naked flames, hot surfaces and sources of ignition.
- ▶ Avoid contact with skin and eyes.

After inhalation

Take in fresh air. Immediately consult a doctor in case of any discomfort.

After skin contact

- ▶ Wash affected skin with soap and water and rinse well. Remove contaminated clothing. Consult doctor in the event of pain or discomfort.

After contact with eyes

- ▶ Rinse eyes under flowing water for at least ten minutes with the lids open; also rinse under lids. Immediately consult a doctor in case of any pain or discomfort.

After swallowing

- ▶ Rinse out mouth with water. Never induce vomiting. Risk of aspiration!
- ▶ If a person is lying on their back and is vomiting, place them in the recovery position. Seek medical advice immediately.

Environmental protection measures

- ▶ Never allow brake fluid to flow into the sewage system, water courses or groundwater.
 - ▶ Notify the relevant authorities if fluid penetrates the ground, water courses or the sewage system.
-

CAUTION
Hazard for the environment due to leaking brake fluid

Brake system brake fluid is toxic and harmful to the environment. Brake fluid will contaminate if it enters the sewers or groundwater.

- ▶ Repair the brake system immediately if brake fluid leaks out. Contact your specialist dealer.
- ▶ Dispose of leaked brake fluid in an environmentally responsible way as per statutory regulations. Contact your specialist dealer.

2.2 Requirements for the rider

The rider must demonstrate adequate physical, motor and mental abilities to ride on public roads.

2.3 Vulnerable groups

If minors use the bicycle, a legal guardian must provide them with comprehensive instructions.

2.4 Personal protective equipment

Wear a suitable cycling helmet, sturdy footwear and typical close-fitting clothing for bicycles.

2.5 Safety markings and safety instructions

The nameplate contains these safety markings and safety instructions:



Symbol	Explanation
	General warning
	Adhere to the instructions for use

Table 2: Meaning of safety markings

2.6 Emergency

2.6.1 What to do in an emergency

- ▶ Apply the bicycle brakes until the bicycle comes to a halt if you should face any danger on the road. The brake acts as an emergency stop system in such cases.

2.6.2 Leaking fluids

2.6.2.1 Brake fluid

- ▶ The brake system must be repaired immediately if brake fluid leaks out. Contact your specialist dealer.
- ▶ Dispose of leaking brake fluid in an environmentally responsible way in accordance with statutory regulations. Contact your specialist dealer.

2.6.2.2 Oils and lubricants from the fork

- ▶ Dispose of oils and lubricants which have leaked from the rear frame damper in an environmentally responsible way in compliance with statutory regulations. Contact your specialist dealer.

2.6.2.3 Oils and lubricants from the rear frame damper

- ▶ Dispose of oils and lubricants which have leaked from the rear frame damper in an environmentally responsible way in accordance with statutory regulations. Contact your specialist dealer.

3 Overview

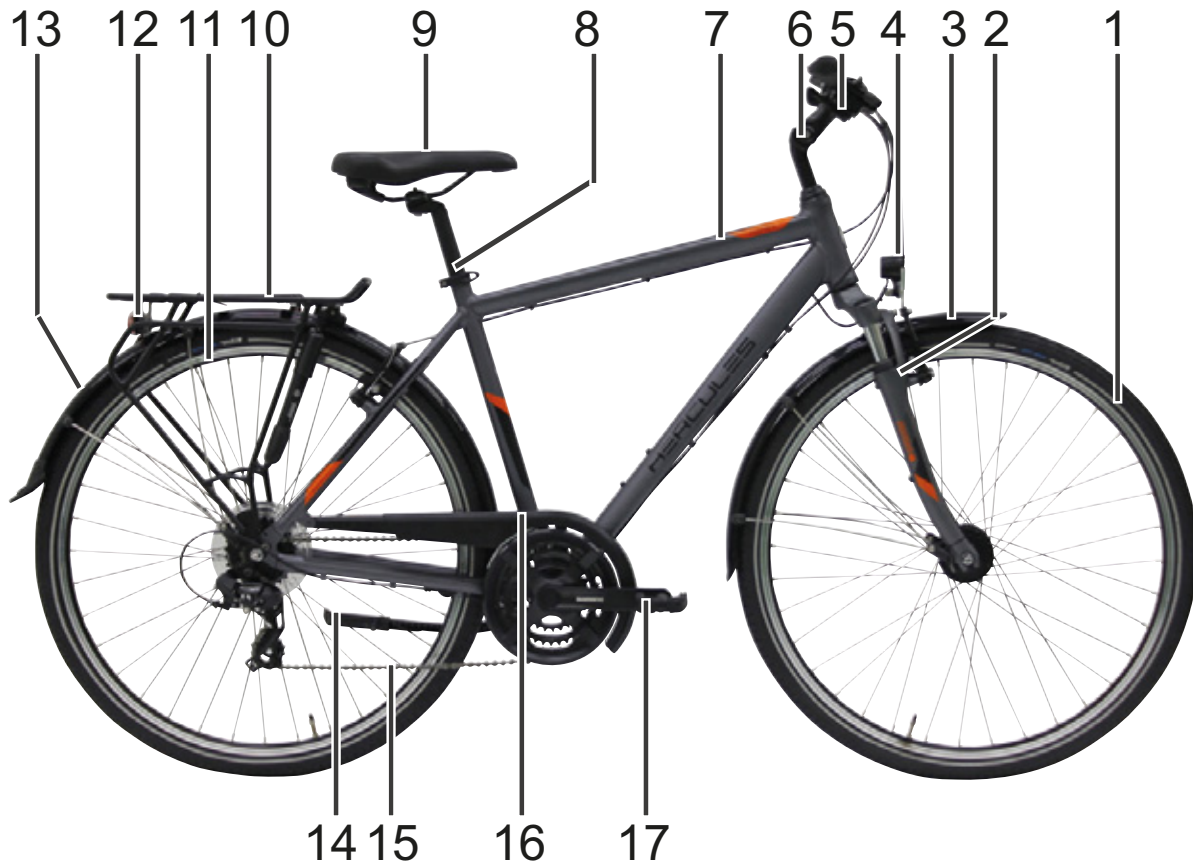

Figure 1: Bicycle viewed from the right – example

1	Front wheel	10	Pannier rack
2	Fork	11	Rear wheel
3	Front guard	12	Rear light
4	Headlight	13	Rear guard
5	Handlebars	14	Kickstand
6	Stem	15	Chain
7	Frame	16	Chain guard
8	Seat post	17	Pedal
9	Saddle		

3.1 Description

3.1.1 Wheel

The bicycle has two wheels: a front wheel and a rear wheel.

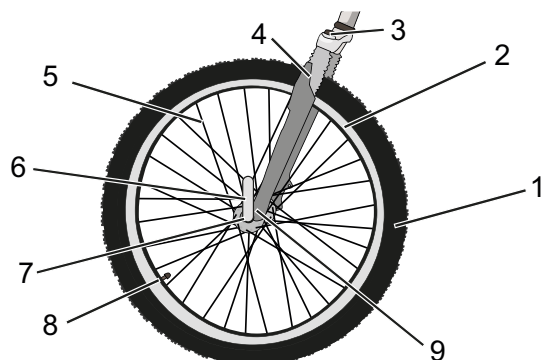

Figure 2: Visible wheel components – front wheel used as an example

1	Tyre	6	Quick release
2	Rim	7	Hub
3	Fork head	8	Valve
4	Fork leg	9	Fork end of fork leg
5	Spoke		

3.1.1.1 Valve

Each wheel has a valve. It is used to fill the *tyre* with air. There is a valve cap on each valve. The screw-on valve cap keeps out dust and dirt.

The bicycle either has a classical *Dunlop valve*, a *Presta valve* or a *Schrader valve*.

3.1.2.1 Rigid fork

Rigid forks do not feature suspension. They transfer the used muscle and motor power to the road to optimum effect. Bicycles with rigid forks consume

3.1.2.2 Suspension fork

A suspension fork is based either on a steel spring or air suspension.

Unlike a rigid fork, a suspension fork has two functions which improve floor contact and comfort: suspension and damping. The suspension prevents an impact, such as one caused by a stone lying in the bicycle's path, from being channelled directly into the rider's body via the fork. The impact is absorbed by the suspension system instead. This causes the suspension fork to compress.

Figure 3: Bicycle without suspension (1) and with suspension (2)

3.1.2 Suspension

Both forks and suspension forks are fitted in this model series.

less energy on steep roads and have a greater range than bicycles with adjusted suspension.

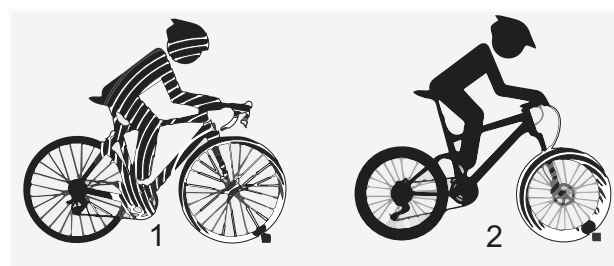

After compressing, the suspension fork returns to its original position. If there is a damper, it decelerates movement, preventing the suspension system from springing back in an uncontrolled manner and stopping the fork from vibrating up and down. Dampers which dampen compressive deflection movements, i.e. a compression load, are called compression dampers or compression dashpots.

Dampers which dampen rebound deflection movements, i.e. a rebound load, are called rebound dampers or dashpots.

The compression can be disabled in any suspension fork. A suspension fork will then behave like a rigid fork.

3.1.2.3 Steel suspension fork

The stem and handlebars are fastened to the fork steerer (1). The wheel is fastened to the quick release axle (6).

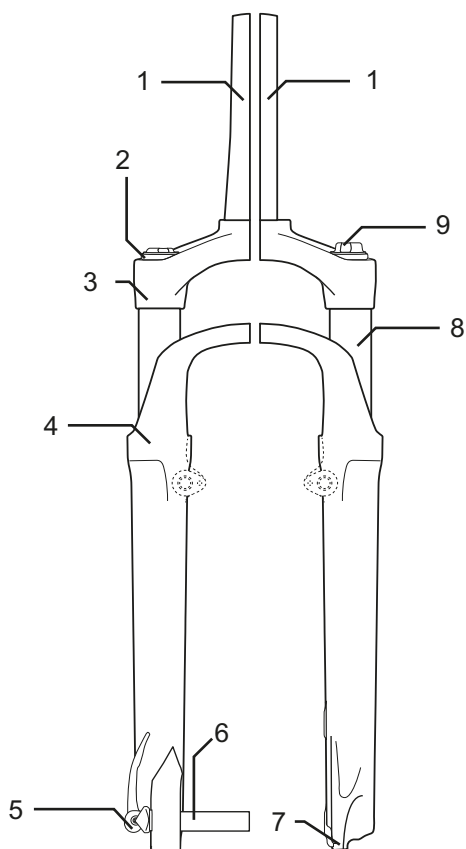

Figure 4: Example showing Suntour fork

Other elements: the setting wheel for negative deflection (9), crown (3), Q-Loc (5), dust seal (4), fork end (7) and stanchion (8)

3.1.2.4 Air suspension fork

The air suspension fork features air suspension and a compression damper plus a rebound damper in some cases.

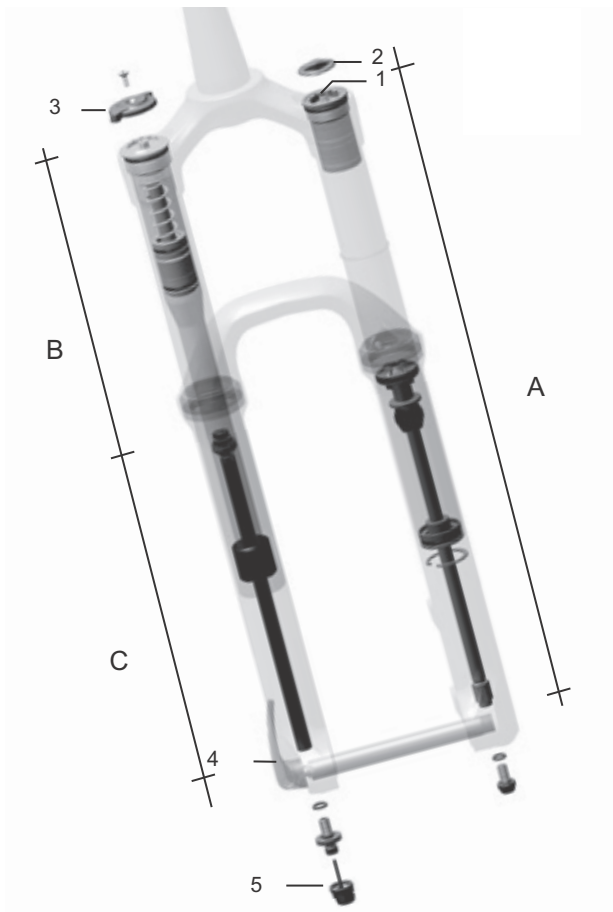

Figure 5: Example showing Yari fork

You can see these components in the diagram: Air valve (1), valve cap (2), fork lock (3), quick release (4) and rebound damper adjuster (5) and the assembly groups: Air suspension fork (A), compression damper assembly group (B) and rebound damper assembly group (C)

3.1.2.5 Suntour rear frame damper

The rear frame damper features air suspension, a compression damper and a rebound damper.

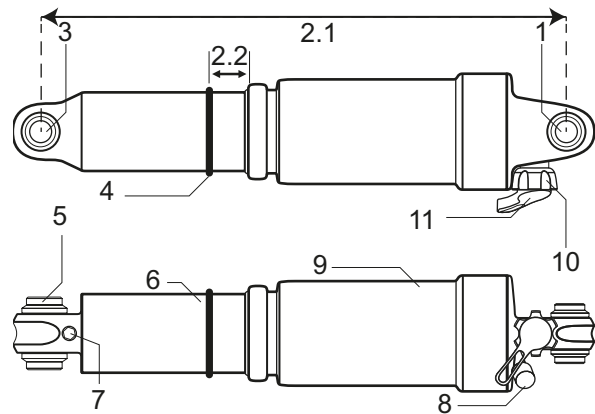

Figure 6: Example showing Suntour rear frame damper

- 1 Upper eye
- 2.1 Total damper length
- 2.2 Negative deflection in the rear frame damper
- 3 Lower eye
- 4 O-ring
- 5 Sleeve
- 6 Damper unit
- 7 IFP (internal floating piston)
- 8 Air valve
- 9 Air chamber
- 10 Lockout lever
- 11 Rebound lever (rebound setting)

3.1.2.6 FOX rear frame damper

The rear frame damper features air suspension, a compression damper and a rebound damper.

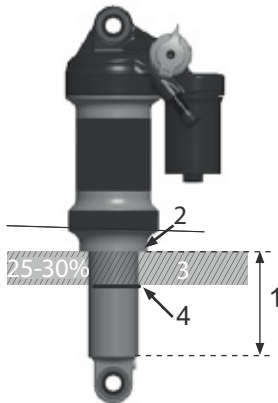

Figure 7: Example showing FOX rear frame damper

- 1 Guide rod eye
- 2 Air valve
- 3 Setting wheel
- 4 Lever
- 5 Air chamber
- 6 O-ring

3.1.3 Brake system

Every bicycle has a hydraulic brake system. The brake fluid is in a closed hose system. If the rider pushes the brake lever, the brake fluid activates the brake on the wheel.

The bicycle has either:

- a rim brake on the front and rear wheels
- a disc brake on the front and rear wheels or
- a rim brake on the front and rear wheels and an additional back-pedal brake.

The mechanical brakes are used as an emergency stop system and bring the bicycle to a halt quickly and safely in the event of an emergency.

3.1.3.1 Rim brake

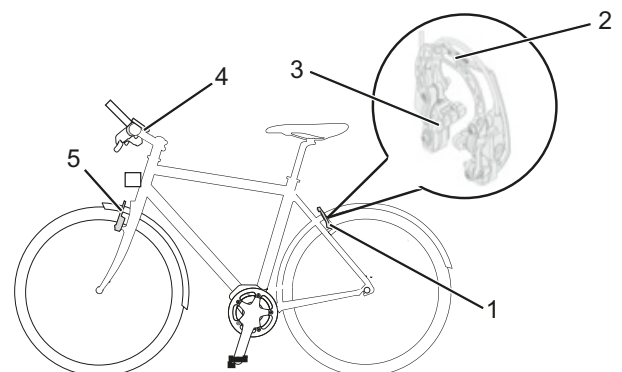

Figure 8: Brake system with rim brake in detail – Magura HS22 used as an example

- 1 Rear wheel rim brake
- 2 Brake booster
- 3 Brake lining
- 4 *Handlebars with brake lever*
- 5 Front wheel rim brake

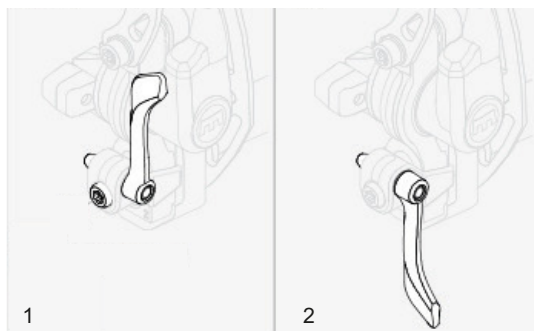

Figure 9: Rim brake locking lever, closed (1) and open (2)

The rim brake stops the wheel moving when the rider pushes the *brake lever*, causing two brake linings, positioned opposite one another, to be pressed onto the *rims*. The hydraulic rim brake

features a locking lever. The rim brake locking lever is not marked with any lettering. Only a specialist dealer may set the rim brake locking lever.

3.1.3.2 Disc brake

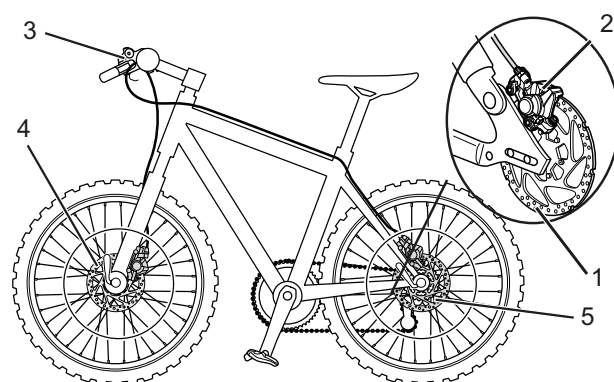

Figure 10: Brake system with disc brake – example

- 1 Brake disc
- 2 Brake calliper with brake linings
- 3 *Handlebars with brake lever*
- 4 Front wheel brake disc
- 5 Rear wheel brake disc

On a bicycle with a disc brake, the brake disc is screwed permanently to the *hub* of the wheel.

The *brake lever* is pushed to increase brake pressure. The brake fluid is used to transfer pressure through the brake lines to the cylinders in the brake calliper. The braking force is boosted by a speed reduction and applied to the brake linings. These apply the brake disc mechanically. If the *brake lever* is pushed, the brake linings are pressed against the brake disc and the wheel movement is decelerated until it comes to a stop.

3.1.3.3 Back-pedal brake



Figure 11: Brake system with a back-pedal brake – example

- 1 Rear wheel rim brake
- 2 *Handlebars with brake lever*
- 3 Front wheel rim brake
- 4 *Pedal*
- 5 Back-pedal brake

The back-pedal brake stops the movement of the rear wheel when the rider pedals in the opposite direction to the direction of travel.

3.2 Proper use

The bicycle may only be used in a perfect, fully functional condition. National requirements may apply to the bicycle which differ from the standard equipment. For riding on public roads, some special regulations apply in relation to the riding light, reflectors and other components.

The general laws and the regulations for the prevention of accidents and environmental

protection in the respective country of use must be adhered to. All check lists and instructions for actions in these *operating instructions* must be observed. Approved accessories can be installed by specialist staff.

Each bicycle is assigned a bicycle type, which determines its proper use, function and area of use.







City and trekking bicycles	Child's bicycles/ bicycles for young adults	Mountain bikes	Racing bicycle	Cargo bike	Folding bicycle
					
<p>City and trekking bicycles are designed for daily, comfortable use. They are suitable for riding on public roads.</p>	<p>The legal guardians of minor riders must read and understand these <i>operating instructions</i> before putting the bicycle into use.</p> <p>The content of these <i>operating instructions</i> must be communicated to the riders in an age-appropriate manner.</p> <p>The cycles for children and young adults are suitable for riding on public roads. The size of the cycle must be checked regularly for orthopaedic reasons.</p> <p>A check must be made at least every three months to make sure that the maximum permitted total weight is being observed.</p>	<p>Mountain bikes are designed for sporting use. The design characteristics include a short wheelbase, a sitting position with the rider inclined towards the front, and a brake requiring low actuation force.</p> <p>A mountain bike is a piece of sporting equipment. It requires an adaptation period as well as physical fitness. Use requires the appropriate training; in particular riding in bends and braking should be practised.</p> <p>The strain on the rider, in particular the hands and wrists, arms, shoulders, neck and back, is accordingly high. Inexperienced riders tend to brake excessively and lose control as a result.</p>	<p>A racing bicycle is designed for fast rides on roads and paths with a good, undamaged road surface.</p> <p>A racing bicycle is a piece of sporting equipment and not a means of transport. A racing bicycle is characterised by its lightweight structure and a design which is stripped to the minimum parts required for riding.</p> <p>The frame geometry and the layout of the operating elements are designed in such a way that the bicycle can be ridden at high speeds. The frame design requires practice to ensure the ride is able to ride slowly, apply the brakes and get on and off the bike safely.</p> <p>The sitting position is athletic. The strain on the rider, in particular the hands and wrists, arms, shoulders, neck and back, is accordingly high. The sitting position therefore requires physical fitness.</p>	<p>The cargo bike is suitable for daily transportation of loads on public roads.</p> <p>The transportation of loads requires skill and physical fitness in order to balance the additional weight. The very varied loading conditions and weight distributions require special practice and skill when braking and riding in bends.</p> <p>A longer period is required to adaptation to the length, width and turning circle. You need to be cautious when riding a cargo bike. You must pay attention to the traffic on public roads and the condition of the route accordingly.</p>	<p>The folding bicycle is suitable for use on public roads.</p> <p>A folding bicycle can be folded up and is thus suitable for space-saving transportation, for example on public transport or in a car.</p> <p>The folding function of the folding bicycle makes it necessary to use smaller wheels and longer brake cables and Bowden cables. Therefore, in case of an increased load, a reduction in riding stability and braking power, diminished comfort and reduced durability are to be expected.</p>

Table 3: Proper use for each bicycle type

3.3 Improper use

Failure to adhere to the proper use poses a risk of personal injury and material damage. It is prohibited to use the bicycle in the following ways:

- when the electrical drive system has been manipulated
- riding with a damaged or incomplete bicycle
- riding over steps
- riding through deep water
- lending the bicycles to untrained riders
- carrying other people
- riding with excessive baggage
- riding with no hands
- riding on ice and snow
- improper servicing
- improper repair
- tough areas of use, such as professional competitions
- stunt riding or acrobatics.

City and trekking bicycles	Child's bicycles/ bicycles for young adults	Mountain bikes	Racing bicycle	Cargo bike	Folding bicycle
					
City and trekking bicycles are not sports bicycles. If used for sports, the rider can expect reduced riding stability and diminished comfort	Cycles for children and young adults are not toys.	Mountain bikes must be retrofitted with lighting, a guard and other fittings as specified by national laws and regulations before they are used on public roads.	Racing bikes must be retrofitted with lighting, a guard and other fittings as specified by national laws and regulations before they are used on public roads.	A cargo bike is not a touring bicycle or a sports bicycle.	The folding bicycle is not a sports bicycle.

Table 4: Information on improper use

3.4 Technical data

3.4.1 Bicycle

Transportation temperature	5 °C - 25 °C
Ideal transportation temperature	10 °C - 15 °C
Storage temperature	10 °C - 30 °C
Ideal storage temperature	10 °C - 15 °C
Operating temperature	5 °C - 35 °C
<i>Work environment</i> temperature	15 °C - 25 °C
Charging temperature	0 °C - 40 °C
Power output/system	250 W (0.25 kW)
Shut-off speed	25 km/h

Table 5: Bicycle technical data

3.4.2 Tightening torque

Axle nut tightening torque	35 Nm - 40 Nm
Handlebars clamping screw maximum tightening torque*	5 Nm - 7 Nm

Table 6: Tightening torque values

*if there is no other data on the component

3.5 Environmental requirements

You can ride the bicycle within a temperature range between 5 °C and 35 °C. The electric drive system is limited in its performance outside this temperature range.

Optimal operating temperature	22 °C - 26 °C
--------------------------------------	---------------

Temperatures under -10 °C and over +60 °C must be avoided.

You must also keep within the following temperature ranges:

Transportation temperature	-10 °C - 50 °C
Storage temperature	-10 °C - 50 °C
Work environment temperature	15 °C - 25 °C
Charging temperature	0 °C - 40 °C











Table 7: Bicycle technical data

The nameplate contains symbols for the bicycles' area of use. Check what roads and paths you may use before you ride the bicycle for the first time.

Area of use	City and trekking bicycles	Child's bicycles/ bicycles for young adults	Mountain bikes	Racing bicycle	Cargo bike	Folding bicycle
1	Suitable for tarmacked and paved roads.	Suitable for tarmacked and paved roads.		Suitable for tarmacked and paved roads.	Suitable for tarmacked and paved roads.	Suitable for tarmacked and paved roads.
2	Suitable for tarmacked roads, cycle paths and firm gravel paths and roads, and longer sections with moderate slopes and jumps up to 15 cm.	Suitable for tarmacked roads, cycle paths and firm gravel paths and roads, and longer sections with moderate slopes and jumps up to 15 cm.	Suitable for tarmacked roads, cycle paths and easy to demanding off-road riding, sections with moderate slopes and jumps up to 61 cm.	Suitable for tarmacked roads, cycle paths and firm gravel paths and roads, and longer sections with moderate slopes and jumps up to 15 cm.		
3			Suitable for tarmacked roads, cycle paths and easy to demanding off-road riding, limited downhill use and jumps up to 122 cm.			
4			Suitable for tarmacked roads, cycle paths and easy to extremely difficult off-road riding, unlimited downhill use and any jumps.			

Table 8: Area of use

The bicycle is unsuitable for the following areas of use:

Area of use	City and trekking bicycles	Child's bicycles/ bicycles for young adults	Mountain bikes	Racing bicycle	Cargo bike	Folding bicycle
						
 1	Never drive off-road or perform jumps.	Never drive off-road or perform jumps.		Never drive off-road or perform jumps.	Never drive off-road or perform jumps.	Never drive off-road or perform jumps.
 2	Never drive off-road or perform jumps over 15 cm.	Never drive off-road or perform jumps over 15 cm.	Never drive off-road or perform jumps over 15 cm.	Never drive off-road or perform jumps over 15 cm.		
 3			Never ride downhill or perform jumps over 61 cm.			
 4			Never traverse extremely difficult off-road terrain or perform jumps over 122 cm.			

3.6 Description of controls and screens

3.6.1 Handlebars

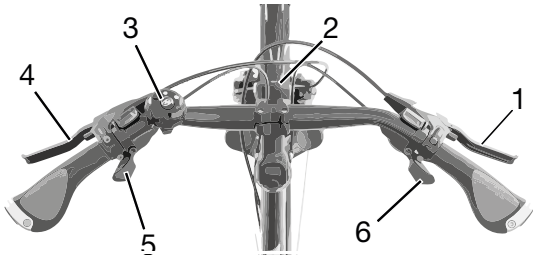

Figure 12: Detailed view of bicycle from rider position

- 1 Rear brake lever
- 2 Headlight
- 3 Bell
- 4 Front brake lever
- 5 Shifter
- 6 Shifter

4 Transporting and storing



4.1 Physical transport characteristics

4.1.1 Dimensions during transportation

There was no information relating to the box dimensions at the time of going to press. You'll find the information in the latest *operating instructions* on the service portal.

4.1.2 Transport weight

There was no information relating to transport weight at the time of going to press. You'll find the information in the latest *operating instructions* on the service portal.

4.1.3 Designated handles/lifting points

The box does not have any handles.

4.2 Transporting

Notice

- ▶ When shipping the bicycle, we recommend that you have the specialist dealer partially dismantle the bicycle and place it in the proper packaging.

- ▶ Transport the bicycle in a dry, clean position where it is protected from direct sunlight.

4.3 Storing

- ▶ Store the bicycle in a clean, dry place where it is protected from direct sunlight. Do not store outdoors to ensure a long service life.

Optimum storage temperature for the bicycle	20 °C
---	-------

Table 9: Storage temperature for batteries and the bicycle

- ✓ Temperatures under -10 °C or over +60 °C must generally be avoided. Storage at about 20 °C is beneficial to a long service life.



5 Assembly

WARNING

Injury to the eyes

Problems may arise if the settings are not made to components correctly and you may sustain serious injuries as a result.

- ▶ Always wear safety glasses to protect your eyes during assembly.

- ✓ Assemble the bicycle in a clean and dry environment.
- ✓ The *work environment* temperature should be between 15 °C and 25 °C.
- ✓ The fitting stand used must be approved for a maximum weight of at least 25 kg.

- ▶ The packaging has to be disposed of in accordance with the regulations of the authorities.

5.2.1 Scope of delivery

The bicycle is fully assembled in the factory for test purposes and then dismantled for transportation.

The bicycle is 95–98% pre-assembled. The scope of delivery includes:

- the pre-assembled bicycle
 - the front wheel
 - the pedals
 - quick release (optional)
- ▶ For this reason, every bicycle must be prepared, so it is fully ready for use immediately after being assembled.
 - ▶ The assembly report (see Section [11.2](#)) describes all safety-relevant inspections, tests and maintenance tasks for the bicycle in a separate list. All assembly work must be completed to ensure the bicycle is ready to ride.
 - ▶ Complete an assembly report for quality assurance purposes.

5.1 Required tools

The following tools are required to assemble the bicycle:

- Knife
- Hexagon socket spanner 2 (2.5 mm, 3 mm, 4 mm, 5 mm, 6 mm and 8 mm)
- Torque wrench with working range between 5 and 40 Nm
- Twelve-point square socket T25
- Ring spanner (8 mm, 9 mm, 10 mm), 13 mm, 14 mm and 15 mm) and
- Cross, flat head and ordinary screwdriver.

5.2 Unpacking

CAUTION

Hand injuries caused by cardboard packaging

The shipping carton is closed with metal staples. There is a risk of puncture wounds and cuts when unpacking and crushing the packaging.

- ▶ Wear suitable hand protection.
- ▶ Remove the metal staples with pliers before the shipping carton is opened.

- the *operating instructions*.

5.3 Commissioning

Only trained specialist staff may perform initial commissioning since putting the bicycle into use requires special tools and specialist knowledge.

Experience has shown that a bicycle which has not yet been sold is automatically handed to customers as soon as it appears ready to ride.

5.3.1 Installing the wheel in the Suntour

fork

5.3.1.1 Screw-on axle (15 mm)

Only applies to Suntour forks with 15 mm screw-on axle

- 1 Insert the axle completely on the drive side.

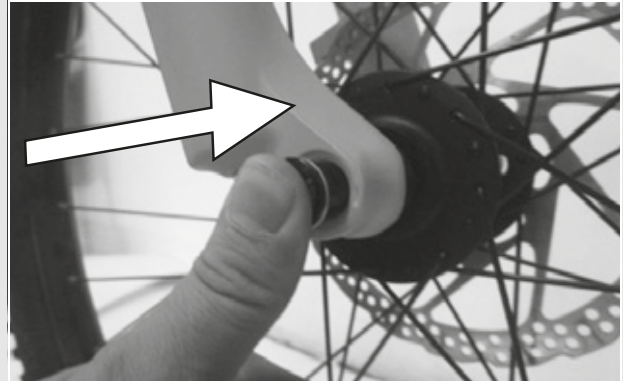

Figure 13: Fully inserting the axle

- 2 Tighten the axle to 8–10 Nm with a 5 mm hexagon socket spanner.

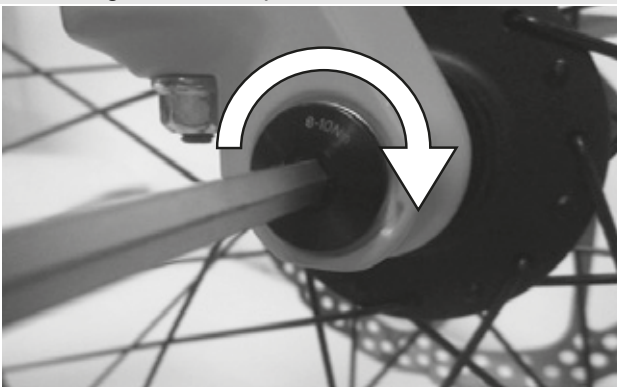

Figure 14: Tightening the axle

- 3 Insert the securing screw on the non-drive side.



Figure 15: Pushing the quick release lever into the axle

- 4 Tighten the securing screw with a 5 mm hexagon socket spanner to 5–6 Nm.

⇒ The lever is mounted.



Figure 16: Tightening the securing screw

5.3.1.2 Screw-on axle (20 mm)

Only applies to Suntour forks with 20 mm screw-on axle

- 1 Insert the axle completely on the drive side.



Figure 17: Tightening the inserted axle

- 2 Tighten the securing clip with a 4 mm hexagon socket spanner to 7 Nm.



Figure 18: Tightening the securing clip

5.3.1.3 Quick release axle

Only applies to Suntour forks with screw-on axle



Crash caused by loose quick release axle

A faulty or incorrectly installed quick release axle may become caught in the brake disc and block the wheel. This will cause a crash.

- ▶ Never fit a defective quick release axle.

Crash caused by faulty or incorrectly installed quick release axle

The brake disc becomes very hot during operation. Parts of the quick release axle may become damaged as a result. The quick release axle becomes loose. This will cause a crash with injuries.

- ▶ The quick release axle and the brake disc must be opposite one another.

Crash caused by incorrectly set quick release axle

Insufficient clamping force will result in unfavourable transmission of force. The suspension fork or the quick release axle may break. This will cause a crash with injuries.

- ▶ Never fasten a quick release axle with a tool, such as a hammer or pliers.

Figure 19: Pushing the axle into the hub

- 1 Insert the axle into the hub on the drive side.

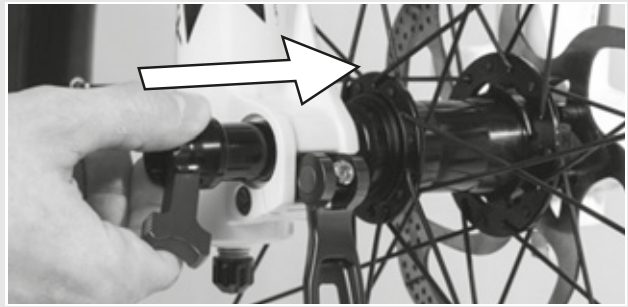

2 Tighten the axle with the red handle.

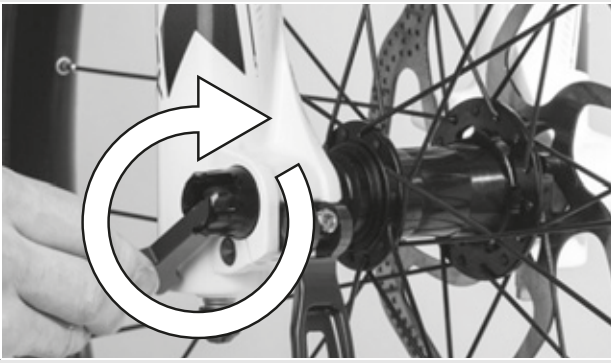

Figure 20: Tightening the axle

3 Push the quick release lever into the axle.

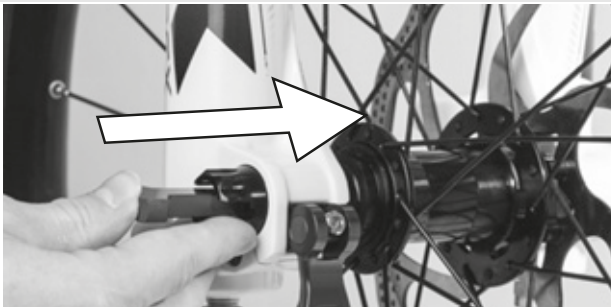

Figure 21: Pushing the quick release lever into the axle

4 Turn the quick release lever.

⇒ The lever is secured.



Figure 22: Securing the lever

- 5 Check the position and clamping force of the quick release lever. The quick release lever must be flush with the lower housing. You must be able to see a slight impression on the palm of your hand when you close the quick release lever.



Figure 23: Perfect position for the clamping lever

- 6 Use 4 mm hexagon socket spanner to adjust the clamping lever clamping force if required.
- 7 Check the quick release lever position and clamping force.

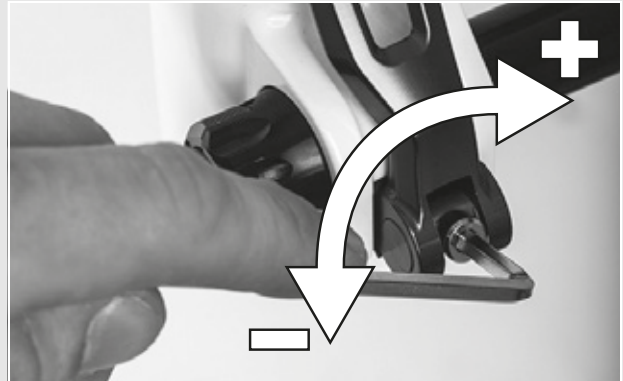

Figure 24: Adjusting the quick release clamping force

5.3.1.4 Quick release

Only applies to Suntour forks with quick release

CAUTION

Crash caused by unfastened quick release

A faulty or incorrectly installed quick release may become caught in the brake disc and block the wheel. This will cause a crash.

- ▶ Never fit a defective quick release.

Crash caused by faulty or incorrectly installed quick release

The brake disc becomes very hot during operation. Parts of the quick release may become damaged as a result. The quick release comes loose. This will cause a crash with injuries.

- ▶ The front wheel quick release lever and the brake disc must be situated on opposite sides.

Crash caused by incorrectly set clamping force

Excessively high clamping force will damage the quick release and cause it to lose its function.

Insufficient clamping force will result in unfavourable transmission of force. The suspension fork or the quick release may break. This will cause a crash with injuries.

- ▶ Never fasten a quick release using a tool (e.g. hammer or pliers).
- ▶ Only use the clamping lever with the specified set clamping force.

Figure 25: Open and closed flange

- 1 Before installing, ensure that the quick release flange is extended. Open the lever fully.

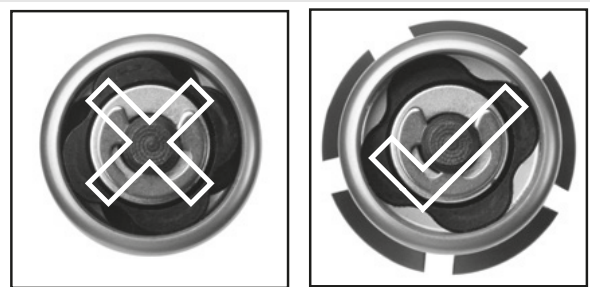

- 2 Push in the quick release until you can hear a click. Make sure that the flange is extended.



Figure 26: Pushing the quick release in

- 3 Adjust tensioning with half-open clamping lever until the flange reaches the fork end.

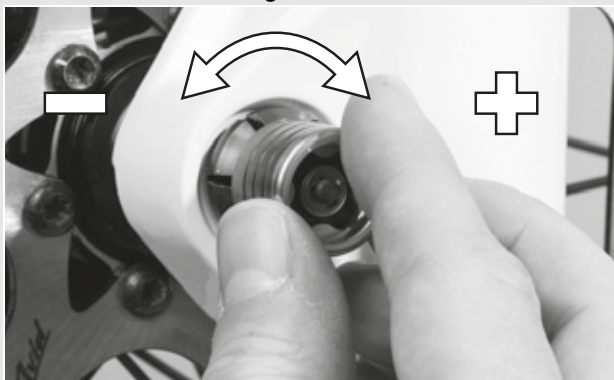

Figure 27: Adjusting the clamping

- 4 Fully close the quick release. Check that the quick release is firmly in place and adjust it on the flange if necessary.

⇒ The lever is secured.



Figure 28: Closing the quick release

5.3.2 Installing the wheel in the FOX fork

5.3.2.1 Quick release (15 mm)

Only applies to FOX forks with 15 mm screw-on axle

The procedure for installing the 15 x 100 mm and 15 x 110 mm quick releases is the same.

- 1 Place the front wheel in the fork ends of the fork. Push the axle through the fork end on the non-drive side and hub.

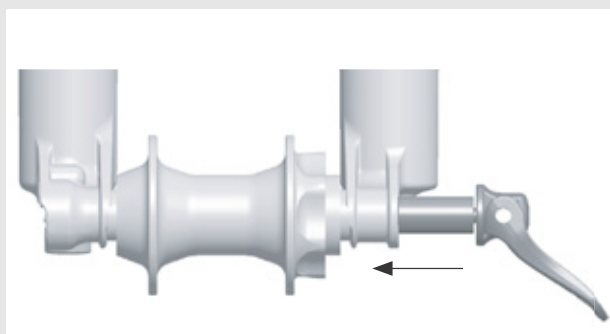

Figure 29: Pushing the quick release in

- 2 Open the axle lever.
- 3 Turn the axle five to six complete revolutions clockwise into the axle nut.
- 4 Close the quick release lever. The lever must be tensioned to the point that it leaves a mark on your hand.

- 5 The lever must be 1 to 20 mm ahead of the fork leg in the closed position.

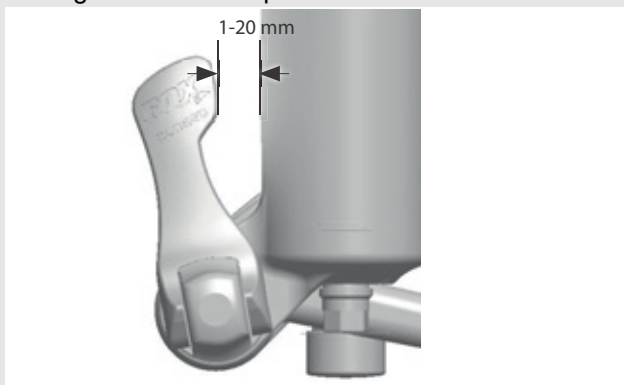

Figure 30: Spacing between lever and fork leg

- ⇒ The quick release must be adjusted if the lever is tensioned inadequately or too strongly when closed in the recommended position (1 to 20 mm in front of the fork).

Setting the quick releases

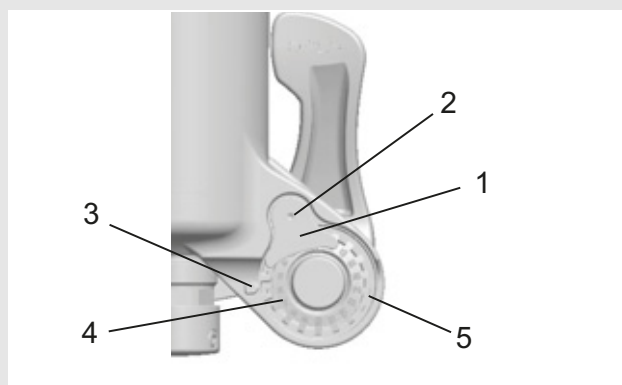

Figure 31: Structure of quick release from rear with (1) axle nut lock and (5) axle nut

- 1 Record the axle setting value (4) indicated by the directional arrow (3).
- 2 Loosen the axle nut securing screw (2) with a 2.5 mm hex key by approx. four revolutions, but do not remove the screw completely.
- 3 Turn the quick release lever to the open position and loosen the axle by approx. four revolutions.
- 4 Press the axle inward from the side of the open lever. This pushes out the axle nut securing screw so that you can turn it out of the way.
- 5 Push the axle further forward and turn the axle nut clockwise to increase the lever tension or anti-clockwise to reduce the lever tension.
- 6 Reinsert the axle nut lock and tighten the screw to 0.9 Nm (8 in-lb).
- 7 Repeat the steps for installing the axle to check proper installation and correct adjustment.

5.3.2.2 Kabolt axle

Only applies to FOX forks with Kabolt axles

The procedure for installing the 15 x 100 mm and 15 x 110 mm Kabolt axles is the same.

- 1 Place the front wheel in the fork ends of the fork. Push the Kabolt axle through the fork end on the non-drive side and hub.

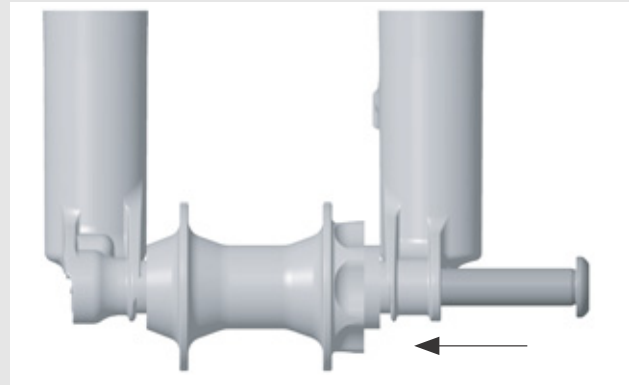

Figure 32: Pushing the Kabolt axle in

- 2 Tighten the Kabolt axle screw to 17 Nm (150 in-lb) with a 6 mm hex key.

5.3.3.1 Checking connections

- 1 Stand in front of the bicycle to check whether the handlebars, fork steerer and fork shaft are firmly attached to one another. Clamp the front wheel between your legs. Grasp the handlebar grips.
 - 2 Try to twist the handlebars towards the front wheel.
- ⇒ The stem must not move or twist.

5.3.3 Checking the stem and handlebars

5.3.3.2 Firm hold

- 1 Place your entire body weight on the handlebars with the quick release lever closed to check that the stem is firmly in place.
- ⇒ The handlebars shaft must not move downwards in the fork steerer.
- 2 If the handlebars shaft should move in the fork steerer, increase the quick release lever tensioning. To do so, turn the knurled nut slightly in a clockwise direction with the quick release lever open.
- 3 Close the lever and check the stem is firmly in position.

5.3.3.3 Checking the headset backlash

- 1 To check the handlebar headset backlash, close the quick release lever on the stem.
 - 2 Place the fingers of one hand on the upper headset cup. Pull the front wheel brake with the other hand and try to push the bicycle backwards and forwards.
 - 3 The headset cup halves must not move towards one another while you are doing this. Note that there may be noticeable backlash due to worn-out bearing bushes or brake lining backlash in suspension forks and disc brakes.
 - 4 If there is headset backlash in the steering headset, you must adjust it as soon as possible; otherwise, the headset will become damaged. You must make the adjustment as described in the stem manual.
- Complete bike pass on the *Operating instructions* cover.
- Adjust the bicycle to the rider; see Section [6.3](#).
- Set the *stand* and the *shifter*.
- Instruct the operator or rider on how to use all the bicycle's functions.

5.4 Selling bicycles

6 Operation

6.1 Risks and hazards



WARNING

Injuries and death caused by other road users

Other road users such as buses, trucks, cars or pedestrians often underestimate the speed of bicycles. Other road users frequently do not see bicycles either. This may lead to an accident with serious injuries or even death.

- ▶ Wear a cycling helmet and high-visibility, reflective clothing.
- ▶ Always take a defensive approach to riding.
- ▶ Avoid the blind spots of vehicles turning off. Reduce speed as a precaution when other road users turn right.



CAUTION

Crash caused by loose clothing

Shoe laces, scarves and other loose items may become entangled in the spokes on the *wheels* and on the *chain drive*. This may cause a crash with injuries.

- ▶ Wear sturdy footwear and close-fitting clothing.

Crash caused by soiling

Heavy soiling can impair the bicycle's functions, such as the brake functions. This may cause a crash with injuries.

- ▶ Remove coarse soiling before riding.

Crash caused by poor road conditions

Loose objects, such as branches and twigs, may become caught in the wheels and cause a crash with injuries.

- ▶ Be aware of the road conditions. Ride slowly and brake in good time.

Notice

Heat or direct sunlight can cause the *tyre pressure* to increase above the permitted maximum pressure. This can destroy the *tyres*.

- ▶ Never park the bicycle in the sun.
- ▶ On hot days, regularly check the *tyre pressure* and adjust it as necessary.

When riding downhill, high speeds may be reached. The bicycle is only engineered for exceeding a speed of 25 km/h briefly. The *tyres* in particular can fail if exposed to a continuous load.

- ▶ Decelerate the bicycle with the brakes if higher speeds than 25 km/h are reached.

Notice

Moisture penetrating at low temperatures may impair individual functions due to the open structural design.

- ▶ Always keep the bicycle dry and free from frost.
- ▶ If the bicycle is to be used at temperatures below 3 °C, the specialist dealer must carry out an inspection and prepare it for winter use.

Off-road riding subjects the joints in the arms to severe strain.

- ▶ Take a break from riding every 30 to 90 minutes, depending on the road surface conditions

6.1.1 Personal protective equipment

It is recommended that you wear a suitable cycling helmet, sturdy footwear and typical, close-fitting, reflective cycling clothing.

6.2 Instruction and customer service

Your supplying specialist dealer will provide customer service. Contact details can be found on the bike pass for these operating instructions. The specialist dealer will explain all the bicycle functions to you in person, this being when the specialist dealer hands over the bicycles at the latest. These operating instructions are provided to you with every bicycle, so that you can consult them at a later stage.

Your specialist dealer will also be happy to assist you in the future whether you require maintenance, conversion or repair.

6.3.1.1 Adjusting the saddle tilt

The saddle tilt must be adjusted to the seat height, the saddle and handlebar position, and the saddle shape to ensure an optimum fit. The seating

- ▶ Place the saddle tilt in the horizontal position to adjust the bicycle to your needs for the first time.

6.3 Adjusting the bicycle



Crash caused by incorrectly adjusted torques

If a screw is fastened too tightly, it may break. If a screw is not fastened enough, it may loosen. This will cause a crash with injuries.

- ▶ Always observe the indicated torques on the screw or in the *operating instructions*.

Only a correctly adjusted bicycle will guarantee the desired ride comfort and health-promoting activity. Therefore adjust the *saddle*, the *handlebars* and the *suspension* to your body and your preferred riding style before the first ride.

6.3.1 Adjusting the saddle

position can be optimised in this way if needed. First, readjust the saddle after finding the handlebar position you prefer.

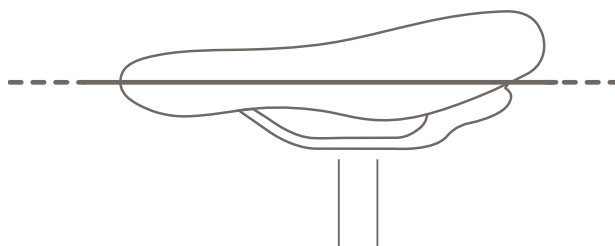

Figure 33: Horizontal saddle tilt

6.3.1.2 Determining the seat height

- ✓ To determine the seat height safely, either push the bicycle near to a wall, so that you can lean on the wall to support yourself or ask another person to hold the bicycle for you.
 - 1 Climb onto the bicycle.
 - 2 Place your heel on the pedal and extend your leg, so that the pedal is at the lowest crank rotation point.
- ⇒ The rider sits straight on the saddle if the seat is at an optimum height. If this is not the case,

you can adjust the length of the seat post to your needs.

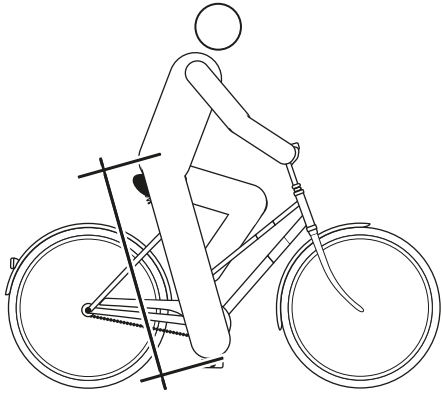

Figure 34: Optimal saddle height

6.3.1.3 Adjusting the seat height with quick release

- 1 Open the quick release on the seat post to change the seat height (1). To do so, push the clamping lever away from the seat post (3).

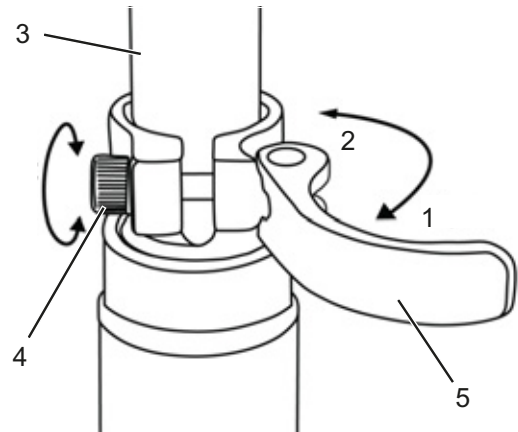

Figure 35: Opening the seat post quick release

- 2 Set the seat post at the required height.

CAUTION

Crash caused by an excessively high seat post setting

A seat post which is set too high will cause the seat post or the frame to break. This will cause a crash with injuries.

- ▶ Do not pull the seat post out of the frame beyond the minimum insertion depth marking.

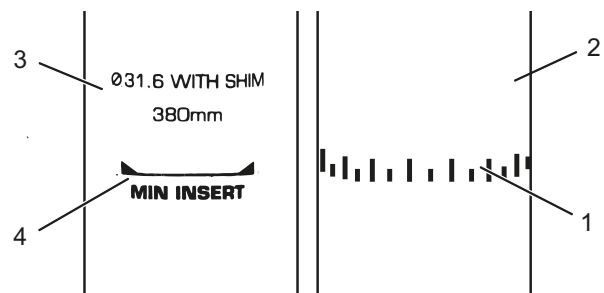

Figure 36: Detailed view of the seat post – examples of the minimum insertion depth marking

- 3 To close it, push the seat post clamping lever as far as it will go into the seat post (2).

- 4 Check the clamping force of quick releases.

⇒ Once you have displaced the post through its deflection, the oil spreads on the seal and the post begins to function normally.

6.3.1.4 Height-adjustable seat post

Only applies to bicycles with this equipment

Preparing

- 1 When using your seat post for the first time, you must give it a firm push downwards to set it in motion. This is due to the natural tendency of the seal to repel oil from the seal surface. You only need to do this before the first use or after a longer period of non-use.

Lowering the saddle

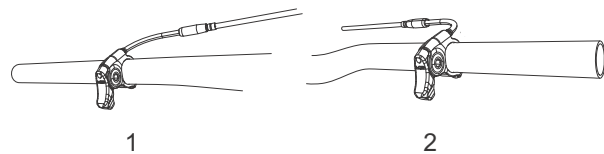

Figure 37: The seat post lever can be installed either on the left (1) or right (2) side of the handlebars

- 1 Press your hand down on the saddle or sit on the saddle to lower the saddle.
- 2 Press the seat post lever and hold it down.

- 3 Release the seat post lever once you have reached the required height.

Raising the saddle

- 1 Press the seat post lever and hold it down.
- 2 Remove any pressure from the saddle.
- 3 Release the seat post lever once you have reached the required height.

6.3.1.5 Adjusting the seat position

The saddle can be shifted on the saddle frame. The right horizontal position ensures an optimal leverage position for legs. This prevents knee pain and painful incorrect pelvis positions. If you have displaced the saddle more than 10 mm, you need to adjust the saddle height again since both settings affect one another.

✓ To adjust the seat position safely, either push the bicycle near to a wall, so that you can lean on the wall to support yourself or ask another person to hold the bicycle for you.

- 1 Climb onto the bicycle.
- 2 Place the pedals into the vertical position with your feet.

The rider is sitting in the optimal sitting position if the knee cap perpendicular line runs through the pedal axle.



- 3.1 If the perpendicular line crosses behind the pedal, bring the saddle forward.
- 3.2 If the perpendicular line crosses in front of the pedal, bring the saddle back.
- 4 Move the saddle within its permitted displacement range only (marked on the saddle stay).

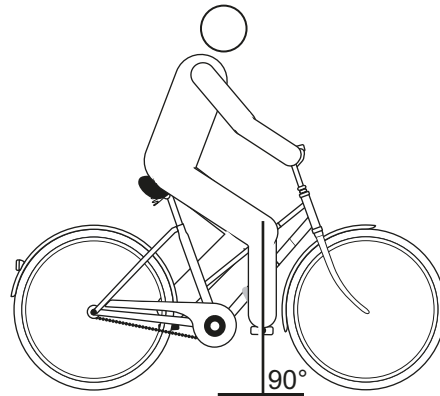

Figure 38: Knee cap perpendicular line

✓ The handlebar settings must only be adjusted while the bicycle is stationary.

- ▶ Unfasten and adjust the designated screw connections, and clamp them with the maximum tightening torque for the clamping screws of the handlebars.



6.3.2 Adjusting the handlebars

⚠ CAUTION

Crash caused by incorrectly set clamping force

Excessively high clamping force will damage the quick release and cause it to lose its function. Insufficient clamping force will result in unfavourable transmission of force. This can cause components to break. This will cause a crash with injuries.

- ▶ Never fasten a quick release using a tool (e.g. hammer or pliers).
- ▶ Only use the clamping lever with the specified set clamping force.

6.3.3 Adjusting the stem

⚠ CAUTION

Crash caused by loose stem

Incorrectly fastened screws may come loose due to impact. The stem may no longer be firmly fixed in its position as a result. This will cause a crash with injuries.

- ▶ Check the handlebars and the quick release system are firmly in position after the first two hours of riding.

6.3.3.1 Adjusting the height of the handlebars

1 Open the **stem clamping lever**.



Figure 39: Open (2) and closed (1) stem clamping lever – by.schulz speedlifter used as an example

2 Pull the **stem clamping lever** upwards while swivelling the handlebars into the required position.

⇒ You feel the locking lever click into place.

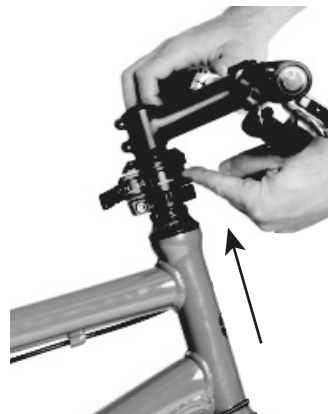

Figure 40: Pulling locking lever upwards – by.schulz speedlifter used as an example

3 Pull out the handlebars to the required height.

4 Close the **stem clamping lever**.

6.3.3.2 Adjusting the quick release clamping force

- ▶ If the *handlebar clamping lever* stops before reaching its end position, unscrew the *knurled nut*.

- ▶ Tighten the *knurled nut* on the seat post if the *seat post clamping lever's* clamping force is not effective enough.
- ▶ If you are unable to set the clamping force, the specialist dealer will need to check the quick release.

6.3.4 Setting the brake

The brake lever grip distance can be adjusted to ensure that it can be reached more easily. The pressure point can also be adjusted to the rider's preferences.

Contact your specialist dealer if there is no description of your brake below.

6.3.4.1 Setting the grip distance on a Magura HS33 brake lever

Only applies to bicycles with this equipment

You can adjust the brake lever position (grip distance) to your requirements. Such adjustment does not affect the pressure point or the position of the brake linings.

- ✓ Use a T25 TORX® wrench to turn the setting screw (1) to adjust the grip distance.

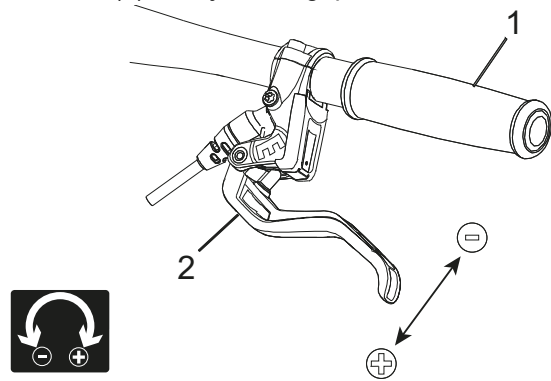

Figure 41: Setting the grip distance on a Magura HS33 brake lever

- ▶ Turn the setting screw anti-clockwise towards minus (-).
 - ⇒ The brake lever moves closer to the handlebar grip.
- ▶ Turn the setting screw clockwise towards plus (+).
 - ⇒ The brake lever moves away from the handlebar grip.

6.3.4.2 Setting the grip distance on a Magura HS22 brake lever

Only applies to bicycles with this equipment

You can adjust the brake lever position (grip

distance) to your requirements.

- ✓ Use a T25 TORX® wrench to turn the setting screw (1) to adjust the grip distance.

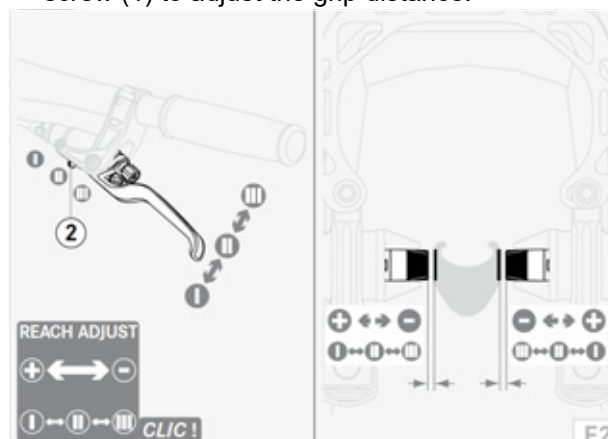

Figure 42: Setting the grip distance on a Magura HS33 brake lever

- ✓ Push the brake lever gently and hold.
- ▶ Move the slider (2) outwards (–) to Position II or III.
 - ⇒ The brake handle moves closer to the handlebars.
 - ⇒ The brake linings move closer to the rim.
- ▶ Move the slider inwards (+) to Position II or I.
 - ⇒ The brake lever moves away from the handlebars.
 - ⇒ The brake linings move away from the rim.
 - ⇒ The pressure point activates later.

WARNING

Crash caused by incorrectly set grip distance

If brake cylinders are set or installed incorrectly, braking power may be lost completely at any time. This may cause a crash with serious injuries.

- ▶ Once the grip distance has been set, check the position of the brake cylinder. Correct if necessary.

6.3.4.3 Setting the grip distance on a

Magura disc brake lever

Only applies to bicycles with this equipment



WARNING

Crash caused by incorrectly set grip distance

If brake cylinders are set incorrectly or installed wrongly, the braking power may be lost at any time. This may cause a crash with injuries.

- ▶ Ensure that the fully applied brake lever is at a minimum distance of 20 mm from the handlebars (4).

You can adjust the brake lever position (grip distance) to your requirements. Such adjustment

Figure 43: Setting the grip distance on a Magura disc brake lever

- ▶ Turn the setting screw/twist knob (5) anti-clockwise towards minus (-).
 - ⇒ The brake lever moves closer to the handlebar grip.
- ▶ Turn the setting screw clockwise towards plus (+).
 - ⇒ The brake lever moves away from the handlebar grip.

does not affect the pressure point or the position of the brake linings.

- ✓ Use a T25 TORX® wrench to turn the setting screw (1) to adjust the grip distance.



6.3.4.4 Setting the pressure point on a Magura brake lever



Brake failure due to incorrect setting

If the pressure point is set with brakes where the brake linings and brake disc have reached their wear limit, the brakes may fail and cause an accident with injury.

- ▶ Before you set the pressure point, ensure that the brake linings and brake disc have not reached their wear limit.

The pressure point setting is adjusted using the twist knob.

- ▶ Turn the twist knob towards the plus (+) symbol.
- ⇒ The *brake lever* moves closer to the handlebar grip. Re-adjust the grip distance as necessary.

- ⇒ The lever pressure point activates sooner.

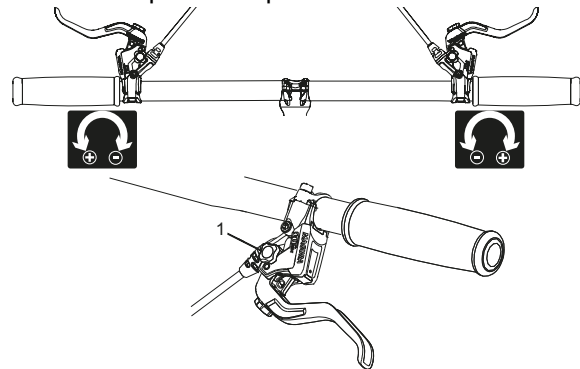

Figure 44: Using the twist knob (1) to adjust the pressure point

6.3.5 Retracting the brake linings

Disc brakes require wearing-in time. The braking force increases over time. You therefore need to be aware that the braking force may increase during the wearing-in period. The same happens after brake pads or discs are replaced.

- 1 Accelerate bicycle to about 25 km/h.
 - 2 Brake bicycle until it comes to a halt.
 - 3 Repeat process 30–50 times.
- ⇒ The disc brake is retracted and provides optimal braking power.

6.3.6 Adjusting the Suntour fork

Only applies to bicycles with this equipment



Crash caused by incorrectly set suspension

If the suspension is set incorrectly, the fork may become damaged, so that problems may occur when steering. This will cause a crash with injuries.

- ▶ Never ride the bicycle without air in the air suspension fork.
- ▶ Never use the bicycle without adjusting the suspension fork to the rider's weight.

Notice

Settings on the chassis change riding performance significantly. You need to get used to the bicycle and break it in to prevent accidents.

The adjustment shown here represents a basic setting. The rider should change the basic setting to suit the surface and his/her preferences.

- ▶ It is advisable to make a note of the basic setting. This way, it can be used as the starting point for subsequent, optimised settings and to safeguard against unintentional changes.

6.3.6.1 Adjusting the negative deflection

Negative deflection depends on the rider's weight and sitting position. The recommended negative

deflection is between 15% (hard) and 30% (soft) of the *total fork deflection*.

6.3.6.2 Adjusting the steel suspension fork negative deflection

Only applies to bicycles with this equipment

You can adjust the tensioning in the fork spring to the rider's weight and their preferred riding style. This reduces the negative deflection in the fork.



Figure 45: Negative deflection setting wheel on the suspension fork crown

- 1 You will find the **negative deflection setting wheel** beneath the plastic cover on the **crown**.

Remove the plastic cover.
Turn the **negative deflection setting wheel** in a

clockwise direction to increase the spring pre-tensioning.

Turn the **negative deflection setting wheel** in an anti-clockwise direction to decrease the spring pre-tensioning.

⇒ You will have made the ideal setting when the shock absorber deflects 3 mm when subject to the rider's weight.

3 Replace the plastic cover on the **crown** after making the setting.

6.3.6.3 Adjusting the air suspension fork negative deflection

Only applies to bicycles with this equipment

► The **air valve** is located beneath the **valve cap** on the **crown** of the left-hand shock absorber. Unscrew the **valve cap**.



Figure 46: Screw caps in different designs

- 1 Attach a high-pressure damper pump to the **air valve**.
- 2 Pump air suspension fork to the required pressure. Observe the levels in the **Suntour filling pressure table**. Never exceed the recommended **maximum air pressure**.

Rider weight	AION, NEX	XCR 32, XCR 34
< 55 kg	35 - 50 psi	40 - 55 psi
55 - 65 kg	50 - 60 psi	55 - 65 psi
65 - 75 g	60 - 70 psi	65 - 75 psi
75 - 85 kg	70 - 85 psi	75 - 85 psi
85 - 95 kg	85 - 100 psi	85 - 95 psi
< 100 kg	+ 105 psi	+ 100 psi
Maximum air pressure	150 psi	180 psi

Table 10: Suntour filling pressure table for air forks

- 3 Detach high-pressure damper pump.
- 4 Measure the distance between the **crow** and the **dust seal**. This distance is *total deflection* of the fork.

6.3.6.4 Adjusting the air suspension fork rebound

Only applies to bicycles with this equipment

The *rebound* setting depends on the *negative deflection* setting: A higher negative deflection requires a lower rebound setting.

- 1 Turn the **Suntour rebound screw** in a clockwise direction to the closed position until it stops.

Figure 47: Suntour rebound screw (2), fork (1)

- 2 Turn the **Suntour rebound screw** slightly in an anti-clockwise direction.
- 3 Adjust the rebound in such a way that the fork rebounds quickly, but without bottoming out upward. Bottoming out refers to when the fork rebounds too quickly and stops moving abruptly once it has reached the full rebound distance. You can hear and feel a slight impact when this happens.

- 5 Push a temporarily attached cable tie downward against the **dust seal**.
- 6 Put on your normal cycling clothing, including luggage.
- 7 Sit on the bicycle in your usual riding position and support yourself against an object, such as a wall or tree.
- 8 Get off the bicycle without allowing it to deflect.
- 9 Measure distance between the **dust seal** and the cable tie.
 - ⇒ This measurement is the negative deflection. The recommended value is between 15% (hard) and 30% (soft) of the total fork deflection.
- 10 Increase or reduce air pressure until you have reached the desired negative deflection.
 - ⇒ If the negative deflection is correct, turn the **valve cap** in a clockwise direction.
 - ⇒ If you are unable to achieve the desired negative deflection, an internal adjustment may be needed. Contact your specialist dealer.

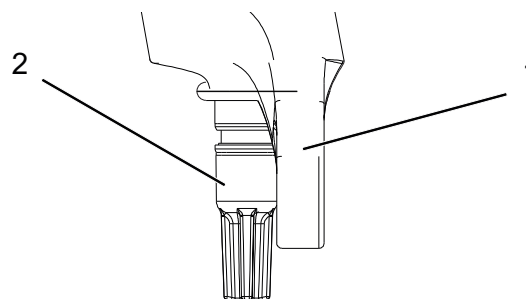

6.3.7 Adjusting the FOX fork

Only applies to bicycles with this equipment



Crash caused by incorrectly set suspension

If the suspension is set incorrectly, the fork may become damaged, so that problems may occur when steering. This will cause a crash with injuries.

- ▶ Never ride the bicycle without air in the air suspension fork.
- ▶ Never use the bicycle without adjusting the suspension fork to the rider's weight.

Notice

Settings on the chassis change riding performance significantly. You need to get used to the bicycle and break it in to prevent accidents.

It is recommended to note down the determined negative deflection and rebound levels. This way, the levels can be used as a starting point for subsequent, optimised settings and as a safeguard against unintentional changes.

The adjustment shown here represents a basic setting. The basic setting can be adjusted to the riding surface and personal preferences.

6.3.7.1 Adjusting the negative deflection

Negative deflection depends on the rider's weight and sitting position. The recommended negative deflection is between 15% (hard) and 20% (soft) of the *total fork deflection* depending on preferences and how the bicycle is used.

- ✓ When adjusting the negative deflection, ensure that each compression adjuster is in an open position, i.e. each compression adjuster has been turned in an anti-clockwise direction until it goes no further.
- ✓ The pressure is to be measured at an ambient temperature of 21 to 24 °C.

- 1 The **air valve** is located beneath a blue **valve cap** on the **crown** of the left-hand shock absorber. Unscrew the **valve cap** in an anti-clockwise direction.
- 2 Attach a high-pressure damper pump to the **air valve**.
- 3 Pump the suspension fork to the required pressure. Observe the levels in the **FOX filling pressure table**. Never exceed the **maximum air pressure** or fall below the **minimum air pressure** recommended in the table.

Rider weight	Rhythm 34	Rhythm 36
Minimum air pressure	40 psi (2.8 bar)	40 psi (2.8 bar)
54 - 59 kg	58 psi	55 psi
59 - 64 kg	63 psi	59 psi
64 - 68 kg	68 psi	63 psi
68 - 73 kg	72 psi	67 psi
73 - 77 kg	77 psi	72 psi
77 - 82 kg	82 psi	76 psi
82 - 86 kg	86 psi	80 psi
86 - 91 kg	91 psi	85 psi
91 - 95 kg	96 psi	89 psi
95 - 100 kg	100 psi	93 psi
100 - 104 kg	105 psi	97 psi
104 - 109 kg	110 psi	102 psi
109 - 113 kg	114 psi	106 psi

Table 11: FOX filling pressure table for air fork

Maximum air pressure	120 psi (8.3 bar)	120 psi (8.3 bar)
----------------------	-------------------	-------------------

Table 11: FOX filling pressure table for air fork

- 4 Detach high-pressure damper pump.
- 5 Measure the distance between the crown and the fork's dust wiper. This distance is *total deflection* of the fork.
- 6 Push the O-ring downwards against the fork's dust wiper. If there is no O- ring, attach a cable tie to the stanchion temporarily.
- 7 Put on your normal cycling clothing, including luggage.
- 8 Sit on the bicycle in your usual riding position and support yourself against an object, such as a wall or tree.

6.3.7.2 Adjusting the rebound

The rebound defines the speed at which the fork rebounds after being loaded. The rebound setting depends on the air pressure setting. A higher *negative deflection* requires a lower rebound setting.

- 1 Turn the **FOX rebound adjuster** in a clockwise direction to the closed position until it stops.

Figure 48: FOX rebound adjuster (1) on the fork end

- 2 Turn the **FOX rebound adjuster** slightly in an anti-clockwise direction.
- 3 Adjust the rebound in such a way that the fork rebounds quickly, but without bottoming out upward. Bottoming out refers to when the fork rebounds too quickly and stops moving abruptly once it has reached the full rebound distance. You can hear and feel a slight impact when this happens.

- 9 Get off the bicycle without the suspension fork deflecting.

- 10 Measure the distance between the dust wiper and the O-ring or cable tie.

⇒ This measurement is the negative deflection. The recommended value is between 15% (hard) and 20% (soft) of the *total fork deflection*.

- 11 Increase or reduce the air pressure until you have reached the desired negative deflection.

⇒ If the negative deflection is correct, turn the blue **valve cap** in a clockwise direction.

If you are unable to achieve the desired negative deflection, internal settings may need to be changed. Contact your specialist dealer.



6.3.8 Setting the Suntour rear frame

damper

Only applies to bicycles with this equipment

6.3.8.1 Adjusting the negative deflection

Notice

If the air pressure in the rear frame damper is exceeded or undershot, the damper can be permanently damaged.

Do not exceed the maximum air pressure of 300 psi (20 bar).

Negative deflection depends on the rider's weight and sitting position. The recommended negative deflection should be between 25% and 30% of the *total rear frame damper deflection*, depending on preferences and how the bicycle is used.

✓ When adjusting the negative deflection, ensure that the compression adjuster is in an open position, i.e. the **lockout lever** is in the OPEN position.

- 1 Remove the valve cap from the **air valve**.
- 2 Attach a high-pressure damper pump.
- 3 Adjust the rear frame damper air pressure to the rider's weight.
- 4 Detach high-pressure damper pump.
- 5 Measure the distance between the air chamber seal and the end of the rear frame damper. This gap is the *total rear frame damper deflection*.

► If the negative deflection is correct, fasten the **valve cap** onto the valve.

- 6 Put on your normal cycling clothing, including luggage.
- 7 Sit on the bicycle in your usual riding position and support yourself against an object, such as a wall or tree.
- 8 Push the O-ring downwards against the air chamber seal.
- 9 Get off the bicycle without the suspension fork deflecting.
 - ⇒ Measure the distance between the air chamber seal and the O-ring. This measurement is the negative deflection. The recommended value is between 25% (hard) and 30% (soft) of the *total rear frame damper deflection*.
- 10 Increase or reduce the air pressure until you have reached the desired negative deflection.

6.3.8.2 Adjusting the rebound

The rebound defines the speed at which the rear frame damper rebounds after being loaded. The rebound setting depends on the air pressure setting. Higher sag settings require lower rebound settings.



Figure 49: Suntour rebound adjuster wheel (1) on the rear frame damper

- ▶ Turn the rebound adjuster wheel towards the – symbol to increase rebounding.
- ▶ Turn the rebound adjuster wheel towards the + symbol to reduce compressive deflection movement.

6.3.8.3 Setting the compression

You can use the pressure damper setting to adjust the rear frame damper to the ground conditions. The pressure damper setting defines the speed at which the rear frame damper rebounds after being subjected to load or impact.

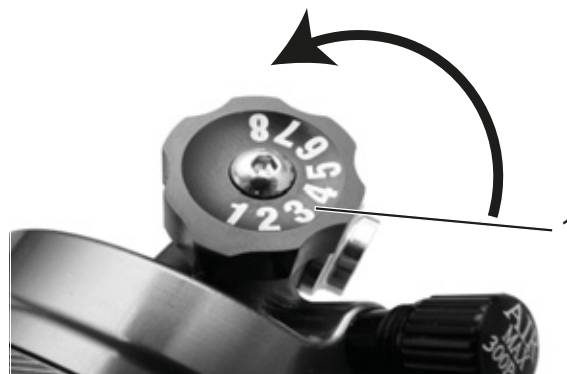

Figure 50: Suntour compression adjuster on the rear frame damper

- ▶ Turn the compression adjuster towards the – symbol to increase rebounding.
- ▶ Turn the compression adjuster towards the + symbol to reduce compressive deflection movement.

6.3.9 Setting the FOX rear frame damper

Only applies to bicycles with this equipment

6.3.9.1 Adjusting the negative deflection

⇒ *Negative deflection* depends on the rider's weight and sitting position. The recommended value is between 25% (hard) and 30% (soft) of the *total rear frame damper deflection*.

- 1 Turn the compression adjuster to the OPEN position.
- 2 Attach a high-pressure damper pump to the air valve.
- 3 Adjust the rear frame damper air pressure to the rider's weight.
- 4 Slowly compress the damper to over 25% of the deflection 10 times until you have reached the desired pressure.

Notice

If the air pressure in the rear frame damper is exceeded or undershot, the damper can be permanently damaged.

Do not exceed the maximum air pressure of 350 psi (24.1 bar). The minimum air suspension pressure of 50 psi (3.4 bar) must be complied with.

- ⇒ This equalises the air pressure between the positive and negative air chambers. The high-pressure damper pump pressure gauge changes.
- 5 Remove the high-pressure damper pump.

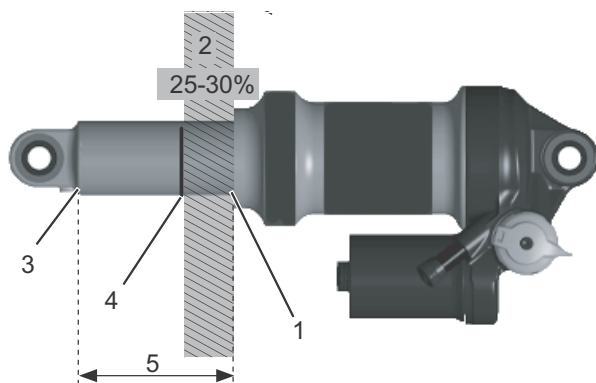

Figure 51: FOX rear frame damper

- 6 Measure the distance between the air chamber seal (1) and the end of rear frame damper (3). This gap is the *total deflection* for the rear frame damper (5).
- 7 Sit on the bicycle in your usual riding position and support yourself against an object, such as a wall or tree.
- 8 Push the O-ring (4) downwards against the air chamber seal (1).
- 9 Get off the bicycle without the suspension fork deflecting.
 - ⇒ Measure the distance between the air chamber seal (1) and the O-ring (4). This measurement is the *negative deflection* (2). The recommended value is between 25% (hard) and 30% (soft) of the *total deflection* for the rear frame damper (5).
- 10 Increase or reduce the air pressure until you have reached the desired negative deflection.

6.3.9.2 Adjusting the rebound

The rebound adjuster defines the speed at which the rear frame damper rebounds after being subjected to load or impact. The rebound setting depends on the air pressure setting. A higher negative deflection requires a lower rebound setting.

- 1 Attach a high-pressure damper pump to the air valve.
- 2 Read the air pressure.
- 3 Remove the high-pressure damper pump.

Figure 52: FOX rebound adjuster wheel (1) on the rear frame damper

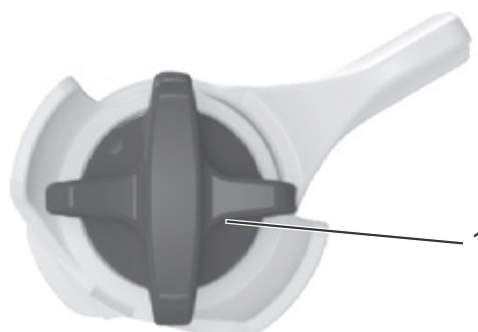

- 4 Turn the rebound adjuster clockwise to the closed position until it stops.
- 5 Adjust the rebound setting based on the air pressure reading. Turn the rebound adjuster back anti-clockwise by the number of clicks specified in the table below.

Air pressure (psi)	Recommended rebound setting
< 100	Open (anti-clockwise)
100 - 120	11
120 - 140	10
140 - 160	9
160 - 180	8
180 - 200	7
200 - 220	6
220 - 240	5
240 - 260	4
260 - 280	3
280 - 300	2

Table 12: Filling pressure table for the FOX air fork

6.4 Accessories

We recommend a parking stand into which either the front wheel or rear wheel can be inserted securely for bicycles which do not have a kickstand. The following accessories are recommended:

Description	Article number
Protective cover for electrical components	080-41000 ff
Panniers, system component*	080-40946
Rear wheel basket system component*	051-20603
Bicycle box system component*	080-40947
Parking stand universal stand	XX-TWO14B

Table 13: Accessories

*System components are matched to the pannier rack and provide sufficient stability due to special transmission of force.

**System components are matched to the drive system.

6.4.1 Child seat

WARNING

Crash caused by incorrect child seat

The pannier rack and down tube are unsuitable for mounting child seats and may break. Such an incorrect position may cause a crash with serious injuries for the rider and the child.

- ▶ Never attach a child seat to the saddle, handlebars or down tube.

CAUTION

Crash caused by improper handling

Using a child seat changes a bicycle's riding performance and stability considerably. This can cause a loss of control, a crash and injuries.

- ▶ You should practice how to use the child seat safely and reliably before using the bicycle in public spaces.

CAUTION

Risk of crushing due to exposed springs

The child may crush his/her fingers on exposed springs or open mechanical parts of the saddle or the seat post.

- ▶ Never install saddles with exposed springs if a child seat is being used.
- ▶ Never install seat posts with suspension with open mechanical parts or exposed springs if a child seat is being used.

Notice

- ▶ Observe the legal regulations on the use of child seats.
- ▶ Observe the operating and safety instructions for the child seat system.
- ▶ Never exceed the maximum permitted total weight.

The specialist dealer will advise on choosing a suitable child seat system for the child and the bicycle.

The specialist dealer must install the child seat the first time to ensure that it is safely fitted.

When installing a child seat, the specialist dealer makes sure that the seat and the fastening mechanism for the seat are suitable for the bicycle and that all components are installed and firmly fastened. The dealer will also ensure that shift cables, brake cables, hydraulic and electrical cables are adjusted as necessary, the rider has optimum freedom of movement and the bicycle's maximum permitted total weight is adjusted.

The specialist dealer will provide instruction on how to handle the bicycle and the child seat.

6.4.2 Bicycle trailer



Crash caused by brake failure

The brake will be weaker if the trailer load is excessive. The long braking distance can cause a crash or an accident and injuries.

- ▶ Never exceed the specified trailer load.

Notice

- ▶ The operating and safety instructions for the trailer system must be observed.
- ▶ The statutory regulations on the use of bicycle trailers must be observed.
- ▶ Only use type-approved coupling systems.

Figure 53: Trailer sign

The specialist dealer will advise on choosing a suitable trailer system for the bicycle. The specialist dealer must install the trailer the first time to ensure that it is safely fitted

A bicycle which is approved for towing a trailer is equipped with the relevant information sign. You may only use bicycle trailers with a support load and weight which do not exceed the permitted values.

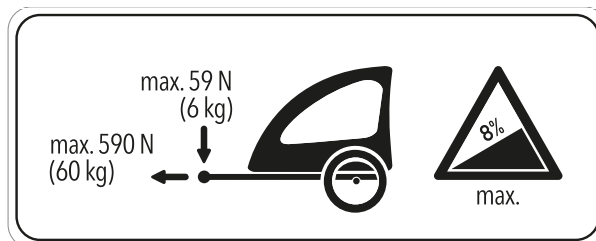

6.4.3 Pannier rack

The specialist dealer will advise on choosing a suitable pannier rack.

The specialist dealer must install the pannier rack the first time to ensure that it is safely fitted.

When installing a pannier rack, the specialist dealer makes sure that the fastening mechanism is suitable for the bicycle and that all components are installed and firmly fastened. The dealer will also ensure that shift cables, brake cables, hydraulic cables and electrical cables are adjusted as necessary, the rider has optimum freedom of movement and the bicycle's maximum permitted total weight adjusted.

The specialist dealer will provide instruction on how to handle the bicycle and the pannier rack.

6.5 Before each ride



Crash caused by difficult-to-spot damage

If the bicycle topples over or you have a fall or an accident, there may be difficult-to-spot damage to components such as the brake system, quick releases or the *frame*. This may cause a crash with injuries.

- ▶ Take the bicycle out of service and have a specialist dealer carry out an inspection.

Crash caused by material fatigue

Intensive use can cause material fatigue. A component may suddenly fail in case of material fatigue. This may cause a crash with injuries.

- ▶ Remove the bicycle from service immediately if there are any signs of material fatigue. Have the specialist dealer check the state.
- ▶ Have the specialist dealer carry out a basic inspection regularly. During the inspection, the specialist dealer inspects the bicycle for any signs of material fatigue on the frame, fork, suspension element mountings (if there are any) and components made of composite materials.

Carbon becomes brittle when exposed to heat radiation such as heating. This can cause the carbon part to break and result in a crash with injuries.

- ▶ Never expose carbon parts to strong heat sources.

6.6 Check list before each ride

- ▶ Check the bicycle before each ride.

⇒ Take the bicycle out of service if you spot any anomalies.

<input type="checkbox"/>	Check that the bicycle is complete.
<input type="checkbox"/>	Check the battery is firmly in place.
<input type="checkbox"/>	Check that the lighting, reflector and brake, for instance, are sufficiently clean.
<input type="checkbox"/>	You must check that the mudguards, the pannier rack and the chain guard are securely installed.
<input type="checkbox"/>	Check that the front and rear wheels run true. This is particularly important if the bicycle has been transported or secured with a lock.
<input type="checkbox"/>	Check the valves and the tyre pressure. Adjust as necessary before each ride.
<input type="checkbox"/>	If the bicycle has a hydraulic rim brake, check whether the locking levers are fully closed in their final positions.
<input type="checkbox"/>	Check the front and rear wheel brakes to make sure that they are working properly. To do so, push the brake levers while stationary to check whether resistance is generated in the usual brake lever position. The brake must not lose any brake fluid.
<input type="checkbox"/>	Check that the riding light is working.
<input type="checkbox"/>	Check for unusual noises, vibrations, smells, staining, deformation, cracks, scores, abrasion and wear. This indicates material fatigue.
<input type="checkbox"/>	Inspect suspension system for cracks, dents, bumps, parts or leaking oil. Look at concealed sections on the bicycle's lower surfaces.
<input type="checkbox"/>	Use body weight to compress suspension system. Adjust to the optimum sag value if suspension is too soft.
<input type="checkbox"/>	If quick releases are used check them to make sure that they are fully closed in their end position. If quick release axle systems are used, make sure that all attachment screws are tightened to the correct torque.
<input type="checkbox"/>	Be alert to any unusual operating sensations when braking, pedalling or steering.
<input type="checkbox"/>	Check that the ABS indicator lamp lights up correctly on bicycles with an ABS system.

6.7 Before each ride



CAUTION

Crash caused by difficult-to-spot damage

If the bicycle topples over or you have a fall or an accident, there may be difficult-to-spot damage to components such as the brake system, quick releases or the *frame*. This may cause a crash with injuries.

- ▶ Take the bicycle out of service and have a specialist dealer carry out an inspection.

Crash caused by material fatigue

Intensive use can cause material fatigue. A component may suddenly fail in case of material fatigue. This may cause a crash with injuries.

- ▶ Remove the bicycle from service immediately if there are any signs of material fatigue. Have the specialist dealer check the state.
- ▶ Have the specialist dealer carry out a basic inspection regularly. During the inspection, the specialist dealer inspects the bicycle for any signs of material fatigue on the frame, fork, suspension element mountings (if there are any) and components made of composite materials.

Carbon becomes brittle when exposed to heat radiation such as heating. This can cause the carbon part to break and result in a crash with injuries.

- ▶ Never expose carbon parts to strong heat sources.

6.8 Check list before each ride

- ▶ Check the bicycle before each ride.

⇒ Take the bicycle out of service if you spot any anomalies.

<input type="checkbox"/>	Check that the bicycle is complete.
<input type="checkbox"/>	Check that the lighting, reflector and brake, for instance, are sufficiently clean.
<input type="checkbox"/>	You must check that the mudguards, the pannier rack and the chain guard are securely installed.
<input type="checkbox"/>	Check that the front and rear wheels run true. This is particularly important if the bicycle has been transported or secured with a lock.
<input type="checkbox"/>	Check the valves and the tyre pressure. Adjust as necessary before each ride.
<input type="checkbox"/>	If the bicycle has a hydraulic rim brake, check whether the locking levers are fully closed in their final positions.
<input type="checkbox"/>	Check the front and rear wheel brakes to make sure that they are working properly. To do so, push the brake levers while stationary to check whether resistance is generated in the usual brake lever position. The brake must not lose any brake fluid.
<input type="checkbox"/>	Check that the riding light is working.
<input type="checkbox"/>	Check for unusual noises, vibrations, smells, staining, deformation, cracks, scores, abrasion and wear. This indicates material fatigue.
<input type="checkbox"/>	Inspect suspension system for cracks, dents, bumps, parts or leaking oil. Look at concealed sections on the bicycle's lower surfaces.
<input type="checkbox"/>	Use body weight to compress suspension system. Adjust to the optimum sag value if suspension is too soft.
<input type="checkbox"/>	If quick releases are used check them to make sure that they are fully closed in their end position. If quick release axle systems are used, make sure that all attachment screws are tightened to the correct torque.
<input type="checkbox"/>	Be alert to any unusual operating sensations when braking, pedalling or steering.

6.9 Using the kickstand



Crash caused by a lowered kickstand

There is a risk of crashing if riding with the kickstand lowered.

- ▶ Raise the kickstand completely before setting off.

Notice

The bicycle's force of weight may cause the kickstand to sink into soft ground, possibly causing the bicycle to topple over as a result.

- ▶ The bicycle must be parked on firm, level ground only.
- ▶ It is particularly important to check that the bicycle is stable when it is equipped with accessories or loaded with baggage.

6.9.1 Raising the kickstand

- ▶ Use your foot to raise the kickstand completely before setting off.

6.9.1.1 Parking the bicycle

- ▶ Use your foot to lower the kickstand completely before parking.
- ▶ Park the bicycle carefully and check that it is stable.

6.10 Using the pannier rack



Crash caused by loaded pannier rack

The riding performance of the bicycle changes with a loaded *pannier rack*, in particular when steering and braking. This can lead to a loss of control. This may cause a crash with injuries.

- ▶ You should practice how to use a loaded *pannier rack* safely and reliably before using the bicycle in public spaces.



Crash caused by unsecured baggage

Loose or unsecured objects on the *pannier rack*, e.g. belts, may become caught in the rear wheel. This may cause a crash with injuries.

Objects which are fastened to the pannier rack may cover the *reflectors* and the *riding light*. The bicycle may be overseen on public roads. This may cause a crash with injuries.

- ▶ Secure any objects which are attached to the *pannier rack* sufficiently.
- ▶ Objects fastened to the *pannier rack* must never cover the *reflectors*, the *headlight* or the *rear light*.

Crushing the fingers in the spring flap

The spring flap on the *pannier rack* operates with a high clamping force. There is a risk of crushing the fingers.

- ▶ Never allow the spring flap to snap shut in an uncontrolled manner.
- ▶ Be careful where you position your fingers when closing the spring flap.

Notice

The maximum load bearing capacity is indicated on the *pannier rack*.

- ▶ Never exceed the maximum permitted *total weight* when packing the pannier.
 - ▶ Never exceed the maximum load bearing capacity of the pannier rack.
 - ▶ Never modify the *pannier rack*.
-
- ▶ Distribute the baggage as evenly as possible between the left- and right-hand side.
 - ▶ We recommend the use of panniers and baggage baskets.

6.11 Brake

WARNING

Crash caused by brake failure

Oil or lubricant on the brake disc in a disc brake or on the rim of a rim brake can cause the brake to fail completely. This may cause a crash with serious injuries.

- ▶ Never allow oil or lubricant to come into contact with the brake disc or brake linings or on the rim of a rim brake.
- ▶ If the brake linings have come into contact with oil or lubricant, contact a dealer or a workshop to have the components cleaned or replaced.

If the brakes are applied continuously for a long time (e.g. while riding downhill for a long time), the fluid in the brake system may heat up. This may create a vapour bubble. This will cause air bubbles or any water contained in the brake system to expand. This may suddenly make the lever travel wider. This may cause a crash with serious injuries.

- ▶ Release the brake regularly when riding downhill for a longer period of time.

Amputation due to rotating brake disc

The brake disc in disc brakes is so sharp that it can cause serious injuries to fingers if they are inserted into the brake disc openings.

- ▶ Always keep fingers well away from the rotating brake discs.

CAUTION

Burns caused by heated brake

The brakes may become very hot during operation. There is a risk of burns or fire in case of contact.

- ▶ Never touch the components of the brake directly after the ride.

- ▶ In order to achieve optimum braking results, do not pedal while braking.

CAUTION

Crash caused by wet conditions

The tyres may slip on wet roads. In wet conditions you must also expect a longer braking distance. The braking sensation differs from the usual sensation. This can cause loss of control or a crash, which may result in injuries.

- ▶ Ride slowly and brake in good time.

Crash caused by incorrect use

Handling the brake improperly can lead to loss of control or crashes, which may result in injuries.

- ▶ Shift your body weight backwards and down as far as possible.
- ▶ Practise braking and emergency braking before the bicycle is used in public spaces.
- ▶ Never use the bicycle if you can feel no resistance when pushing the brake handle. Consult a specialist dealer.

Crash after cleaning or storage

The brake system is not designed for use on a bicycle which is placed on its side or turned upside down. The brake may not function correctly as a result. This can cause a crash, which may result in injuries.

- ▶ If the bicycle is placed on its side or turned upside down, apply the brake a couple of times before setting off to ensure that it functions normally.
- ▶ Never use the bicycle if the brake does not work properly. Consult a specialist dealer.

The drive force of the motor is shut off during the ride as soon as the rider no longer pedals. The drive system does not switch off when braking.

6.11.1 Using the brake lever

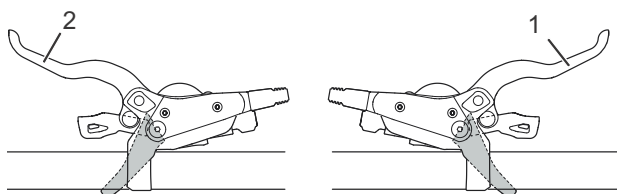

Figure 54: Front (2) and rear (1) brake lever – Shimano brake used as an example

- ▶ Push the left-hand *brake lever* to apply the *front wheel brake*.
- ▶ Push the right-hand *brake lever* to apply the *rear wheel brake*.

6.11.2 Using the back-pedal brake

Only applies to bicycles with this equipment

- 1 Move pedals a little beyond the 3 o'clock and 9 o'clock position.
- 2 Pedal in the opposite direction to the *direction of travel* until the desired speed has been reached.

6.12 Suspension and damping

6.12.1 Adjusting the compression in the Suntour fork

Only applies to bicycles with this equipment

The compression adjuster makes it possible to make quick adjustments to the suspension behaviour of the fork to suit changes in terrain. It is intended for adjustments made during the ride.



Figure 55: Suntour compression adjuster with OPEN (1) and LOCK (2) positions

- ▶ Compression damping is lowest in the OPEN position, making the fork feel softer.
- ▶ Use the lock position if you want the fork to feel stiffer and you are riding on soft ground.
- ▶ The positions between OPEN and LOCK provide fine adjustment of compression damping.

We recommend setting the compression adjuster to the OPEN position first.

6.12.2 Adjusting the compression in the Suntour rear frame damper

[Only applies to bicycles with this equipment](#)

The compression adjuster enables you to make quick adjustments to the suspension behaviour in the rear frame damper to suit changes in terrain. It must never be used while riding on rough terrain.



Figure 56: Suntour compression adjuster open (1)

- Use the OPEN position for rough descents and the LOCK position for efficient climbing. Set the compression adjuster to OPEN first.



Figure 57: Suntour compression adjuster closed (2)

6.12.3 Adjusting the compression in the Fox fork

Only applies to bicycles with this equipment

The compression adjuster makes it possible to make quick adjustments to the suspension behaviour of the fork to suit changes in terrain. It is intended for adjustments made during the ride.

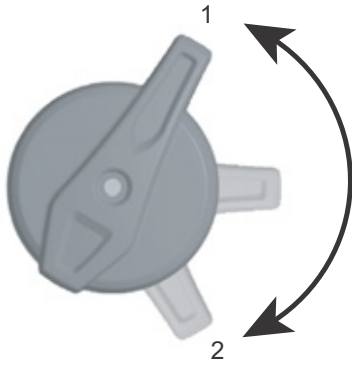

Figure 58: FOX compression adjuster with OPEN (1) and HARD (2) positions

- ▶ Compression damping is lowest in the OPEN position, making the fork feel softer.
- ▶ Use the HARD position if you want the fork to feel stiffer and you are riding on soft ground.
- ▶ The lever positions between the OPEN and HARD positions provide fine adjustment of compression damping.

We recommend setting the compression adjuster lever to the OPEN position first.

6.12.4 Adjusting the compression in the Fox rear frame damper

Only applies to bicycles with this equipment

The compression adjuster enables you to make quick adjustments to the suspension behaviour in the rear frame damper to suit changes in terrain. It is intended for adjustments made during the ride.



Figure 59: FOX compression adjuster on the rear frame damper with OPEN (1), MEDIUM (2) and HARD (3) positions

- ▶ Use the OPEN position for rough descents.
- ▶ Use the MEDIUM position for rough terrain.
- ▶ Use the HARD position for efficient climbing.
- ▶ First turn the compression adjuster to the OPEN position.

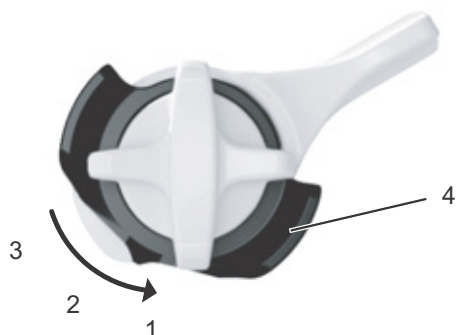

Figure 60: The fine adjuster (4) is used to make fine adjustment to the OPEN position

The FOX rear frame damper features fine adjustment for the OPEN position.

- ✓ We recommend that fine adjustments be made when the compression adjuster is in the MEDIUM or HARD position.

- 1 Pull out the fine adjuster.
- 2 Turn the fine adjuster to position 1, 2 or 3. Setting 1 is for the softest riding performance whereas 3 is for the hardest.
- 3 Press the fine adjuster to lock.

6.12.5 Adjusting the rebound in the RockShox rear frame damper

Only applies to bicycles with this equipment

The rebound damper determines the speed at which the fork rebounds to full length after deflection. This speed affects the wheel's contact with the ground and thus has an influence on control and efficiency. The rear frame damper should rebound fast enough to sustain traction without producing an erratic or bumpy sensation. If rebound damping is too tight, the rear frame damper is unable to rebound fast enough before the next impact. The rebound damper for the rear wheel is located in the rear frame damper.



Figure 61: Setting the rebound damper strength on the rear frame damper setting wheel (1)

- 1 Turn the setting wheel to the middle position.
 - 2 Ride the bicycle over a small obstacle.
- ⇒ The ideal setting for the rebound damper has been achieved when the rebound movement of
- ▶ Turn the setting wheel in an anti-clockwise direction to increase the rebound speed.
 - ▶ Turn the setting wheel in a clockwise direction to decrease the rebound speed.

the rear wheel feels comparable to that of the front wheel.

- 3 If the rear wheel bounces back much more quickly or slowly than the front wheel, change the setting by turning the setting wheel.

6.12.6 Adjusting the compression in a RockShox damper

[Only applies to bicycles with this equipment](#)

The compression damper controls the speed at which the rear frame damper deflects during slow impact, such as smaller impacts or when the rider goes round a corner or shifts their weight. The

compression damper improves control and efficiency.

If the compression damper is set too high, suspension is too hard when exposed to impacts. The damper lever is used to set the compression damper.

- ▶ Turn the setting wheel in a clockwise direction (+) to decrease the deflection speed.
- ▶ Turn the damper lever in an anti-clockwise direction (–) to increase the deflection speed.

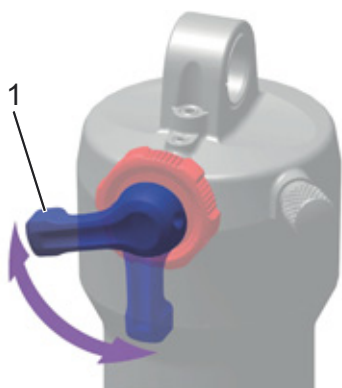

Figure 62: Setting the compression damper hardness using the damper lever (1) for the rear frame damper

6.13 Gear shift

The selection of the appropriate gear is a prerequisite for a physically comfortable ride and

making sure that the electric drive system functions properly. The ideal pedalling frequency is between 70 and 80 revolutions per minute.

- ▶ Stop pedalling briefly when changing gears. This makes it easier to switch gears and reduces wear on the drivetrain.

6.13.1 Using the derailleur gears

Only applies to bicycles with this equipment

The speed and range can be increased while applying the same force if you select the right gear. Use the derailleur gears.

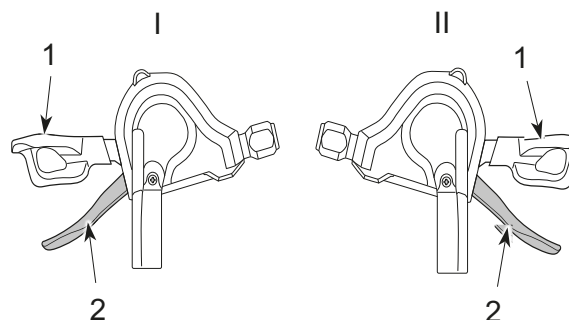

Figure 63: Down shifter (1) and up shifter (2) on the left (I) and right (II) gear shift

- ▶ Select the appropriate gear with the *shifter*.
 - ⇒ The gear shift switches the gear.
 - ⇒ The shifter returns to its original position.
- ▶ Clean and lubricate the rear derailleur if the gear change blocks.

6.13.2 Using the hub gear

Only applies to bicycles with this equipment



CAUTION

Crash caused by incorrect use

If the rider applies too much pressure on the pedals during a gear change and activates the shifter or changes several gears at a time, their feet may slip from the pedals. This may cause a crash or flip-over with injuries.

Switching down several gears to a low gear may cause the twist grip outer sleeve to suddenly come off. This will not have an adverse effect on the twist grip's correct functioning since the outer guide returns to its original position after the gear change is complete.

- ▶ Apply little pressure on the pedals while changing gears.
- ▶ Never change more than one gear at a time.

Notice

The interior hub is not completely waterproof. If water gets into the hub, it may rust and the gear switch function may no longer function as a result.

- ▶ Never use the bicycle in places where water may get into the hub.

In rare cases, noises may be heard from the rear derailleur in the hub interior after a gear change. This is normal when gears are changed.

- ▶ Never detach the hub yourself. Contact your specialist dealer.

Use of the hub gear is described in Figure 64.

- ▶ Turn the twist grip (1) backwards to switch up a gear (4).
- ▶ Turn the twist grip (1) forwards to switch down a gear (2).
- ⇒ The gear shift switches the gear.
- ⇒ The screen display (3) shows the changed gear.

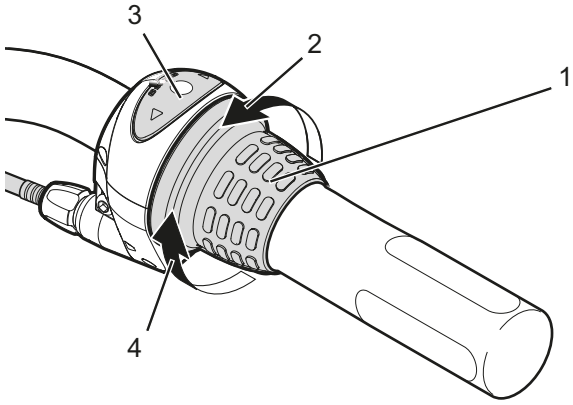

Figure 64: Example: use of Shimano Nexus gear shift

7 Cleaning and servicing

Cleaning check list

<input type="checkbox"/>	Clean the pedals	after each ride
<input type="checkbox"/>	Clean the suspension fork and, if necessary, rear frame damper	after each ride
<input type="checkbox"/>	Chain (mainly tarmacked road)	every 250–300 km
<input type="checkbox"/>	Basic cleaning and preservation of all components	at least every six months
<input type="checkbox"/>	Clean and lubricate the height-adjustable seat post	every six months

Maintenance check list

<input type="checkbox"/>	Check for tyre wear	once a week
<input type="checkbox"/>	Check for rim wear	once a week
<input type="checkbox"/>	Check tyre pressure	once a week
<input type="checkbox"/>	Check brakes for wear	once a month
<input type="checkbox"/>	Check electrical cables and Bowden cables for damage and ensure they are fully functional	once a month
<input type="checkbox"/>	Check chain tension	once a month
<input type="checkbox"/>	Check tension of the spokes	every three months
<input type="checkbox"/>	Check the gear shift setting	every three months
<input type="checkbox"/>	Check suspension fork and, if necessary, rear frame damper for wear and ensure fully functional	every three months
<input type="checkbox"/>	Check for wear on brake discs	at least every six months

Servicing measures must be performed regularly. Contact your specialist dealer if you are unsure.

- ▶ Remove dirt and deposits from the stanchions and deflector seals with a damp cloth.
- ▶ Check the stanchions for dents, scratches, staining or leaking oil.
- ▶ Check the air pressure.
- ▶ Lubricate the dust seals and stanchions.

7.1.2 Cleaning the rear frame damper

- ▶ Remove dirt and deposits from the damper body with a damp cloth.
- ▶ Check rear frame damper for dents, scratches, staining or leaking oil.

7.1.3 Cleaning the pedals

- ▶ Clean with a brush and soapy water after riding through dirt or rain.
- ⇒ Service the pedals after cleaning.

7.1 Cleaning after each ride

Required tools and cleaning agents:

- Cloth
- Air pump
- Brush
- Water
- Dish-washing liquid
- Bucket

7.1.1 Cleaning the suspension fork

7.2 Basic cleaning



CAUTION

Crash caused by brake failure

The braking effect may be unusually poor temporarily after cleaning, servicing or repairs. This may cause a crash with injuries.

- ▶ Never apply care products or oil to the brake discs or brake linings, or the braking surfaces on the rims.
- ▶ After cleaning, servicing or repair, carry out a few test brake applications.

Notice

Water may enter the inside of the bearings if you use a steam jet. This dilutes the lubricant inside, the friction increases and, as a result, the bearings are permanently damaged in the long term.

- ▶ Never clean the bicycle with a pressure washer.

Greased parts, such as the seat post, the handlebars or the stem, may no longer be safely and reliably clamped.

- ▶ Never apply grease or oil to clamping sections.

Required tools and cleaning agents:

- Cloths
- Sponge
- Air pump
- Brush
- Toothbrush
- Paintbrush
- Watering can
- Bucket
- Water
- Dish-washing liquid
- Degreaser
- Lubricant
- Brake cleaner or spirit

- ▶ Clean rear frame damper with a cloth and soapy water.

7.2.1 Cleaning the frame

- 1 Soak the entire frame with dish-washing detergent if the dirt is thick and ingrained.
- 2 After leaving it to soak for a short time, remove the dirt and mud with a sponge, brush and toothbrushes.
- 3 Use a watering can or your hand to rinse the frame.
- 4 Service the frame after cleaning.

7.2.2 Cleaning the stem

- 1 Clean stem with a cloth and soapy water.
- 2 Service the stem after cleaning.

7.2.3 Cleaning the wheel



WARNING

Crash caused by braking hard on rims

A rim can break and block the wheel if you brake hard. This may cause a crash with serious injuries.

Check rim *wear* on a regular basis.

- 1 Check the tyres, rims, spokes and spoke nipples for any damage when cleaning the wheel.
- 2 Use a sponge and a brush to clean the hub and spokes from the inside to the outside.
- 3 Clean the rim with a sponge.

7.2.4 Cleaning the drive elements

- 1 Spray the cassette, the chain wheels and the front derailleur with a degreasing agent.
- 2 Clean coarse dirt with a brush after soaking for a short time.
- 3 Wash down all parts with dish-washing detergent and a toothbrush.
- 4 Service the drive elements after cleaning.

7.2.5 Cleaning the rear frame damper

7.2.6 Cleaning the chain

Notice

- ▶ Never use aggressive (acid-based) cleaners, rust removers or degreasers when cleaning the chain.
- ▶ Never use chain cleaning devices or chain cleaning baths.

- 1 Slightly dampen a brush with dish-washing liquid. Brush both sides of the chain.
- ▶ Carefully clean the drive unit with a damp, soft cloth.

7.2.7 Cleaning the brake



Brake failure due to water penetration

The brake seals are unable to withstand high pressures. Damaged brakes can fail and cause an accident with injury.

- ▶ Never clean the bicycle with a pressure washer or compressed air.
- ▶ Take great care when using a hosepipe. Never point the water jet directly at the seal section.

- ▶ Clean brake and brake discs with a brush, water and dish-washing detergent.
- ▶ Clean brake discs thoroughly with brake cleaner or spirit.

7.3 Servicing

Required tools and cleaning agents:

- Cloths
- Toothbrushes
- Dish-washing liquid
- Care oil for frames
- Silicone or Teflon oil
- Acid-free lubricating grease
- Fork oil
- Chain oil
- Degreaser
- Spray oil
- Teflon spray

- ▶ Dry the frame.
- ▶ Spray with care oil.
- ▶ Clean off the care oil again after a short time.

- 2 Dampen a cloth with soapy water. Place the cloth on the chain.
- 3 Hold and apply slight pressure while slowly turning the rear wheel, so the chain passes through the cloth.
- 4 If the chain is still dirty afterwards, clean with lubricant.
- 5 Service the chain after cleaning.

7.3.1 Servicing the frame

7.3.2 Servicing the stem

- ▶ Apply silicone or Teflon oil to the stem shaft tube and the quick release lever pivot point.
- ▶ If you have speedlifter Twist, also apply oil to the unlocking bolt using the groove in the speedlifter body.
- ▶ Apply a little acid-free lubricant grease between the stem quick release lever and the sliding piece to reduce the quick release lever operating force.

7.3.3 Servicing the fork

- ▶ Treat the dust seals with fork oil.

7.3.4 Servicing the drive elements

- 1 Spray the cassette, the chain wheels and the front derailleur with a degreasing agent.
 - 2 Clean coarse dirt with a brush after soaking for a short time.
- ▶ Treat pedals with spray oil.

7.3.6 Servicing the chain

- ▶ Grease the chain thoroughly with chain oil.

7.3.7 Servicing the drive elements

- ▶ Service front and rear derailleur articulated shafts and jockey wheels with Teflon spray.

7.4 Maintenance

The following maintenance measures must be performed on a regular basis.

7.4.1 Wheel



WARNING

Crash caused by braking hard on rims

A rim can break and block the wheel if you brake hard. This may cause a crash with serious injuries.

- ▶ Check rim *wear* on a regular basis.

Notice

If the tyre pressure is too low in the tyre, the tyre does not achieve its load bearing capacity. The tyre is not stable and may come off the rim.

If the tyre pressure is too high, the tyre may burst.

- ▶ Check the tyre pressure as per specifications
- ▶ *Adjust the tyre pressure* as necessary.

- 1 Check the *tyres* for wear.
- 2 Check the *tyre pressure*.

- 3 Wash down all parts with dish-washing detergent and a toothbrush.

7.3.5 Servicing the pedals

- 3 Check the *rims* for wear.

⇒ The rims of a rim brake with invisible wear indicator are worn as soon as the wear indicator becomes visible in the area of the rim joint.

⇒ The rims with visible wear indicator are worn as soon as the black, all-round groove on the pad friction surface is no longer visible. We recommend that you also replace the *rims* with every second brake lining replacement.

- 4 Check the tension of the spokes.

7.4.1.1 Checking the tyres

- ▶ Check the tyre wear. The tyre is worn if the anti-puncture protection or the carcass cords are visible.
- ⇒ A specialist dealer will need to change the tyre if it is worn.

7.4.1.2 Checking the rims

- ▶ Check the *rims* for wear. The rims are worn as soon as the black, all-round groove on the pad friction surface becomes invisible.
- ⇒ Contact your specialist dealer to have the rims replaced. We recommend that you also replace the *rims* at the same time as every second brake lining replacement.

7.4.1.3 Checking and adjusting the tyre pressure – Dunlop valve

Only applies to bicycles with this equipment

The tyre pressure cannot be measured on the simple Dunlop valve. The tyre pressure is therefore measured in the filling hose when pumping slowly with the bicycle pump.

It is recommendable to use a bicycle pump with a pressure gauge. The operating instructions for the bicycle pump must be adhered to.

- 1 Unscrew and remove the valve cap.
- 2 Connect the bicycle pump.

- 3 Pump up the tyre slowly and pay attention to the tyre pressure in the process.
- 4 Adjust the tyre pressure according to specifications in the bicycle pass.
- 5 If the tyre pressure is too high, unfasten the union nut, let air out and re-tighten the union nut.
- 6 Remove the bicycle pump.
- 7 Screw the valve cap tight.
- 8 Screw the rim nut gently against the rim with the tips of your fingers.

7.4.1.4 Checking and adjusting the tyre pressure – presta valve

Only applies to bicycles with this equipment

✓ It is recommendable to use a bicycle pump with a pressure gauge. The operating instructions for the bicycle pump must be adhered to.

- 1 Unscrew and remove the valve cap.
- 2 Open the knurled nut around four turns.
- 3 Carefully apply the bicycle pump so that the valve insert is not bent.

- 4 Pump up the tyre slowly and pay attention to the tyre pressure in the process.
- 5 Correct the tyre pressure as per the specifications on the tyre.
- 6 Remove the bicycle pump.
- 7 Tighten the knurled nut with your fingers.
- 8 Screw the valve cap tight.
- 9 Screw the rim nut gently against the rim with the tips of your fingers.

7.4.1.5 Checking and adjusting the tyre pressure – Schrader valve

Only applies to bicycles with this equipment

✓ It is recommendable to use a bicycle pump with a pressure gauge. The operating instructions for the bicycle pump must be adhered to.

- 1 Unscrew and remove the valve cap.

- 2 Attach the bicycle pump.
 - 3 Pump up the tyre slowly and pay attention to the tyre pressure in the process.
- ⇒ The tyre pressure has been adjusted as per the specifications.

- 4 Remove the bicycle pump.
- 5 Screw the valve cap tight.
- 6 Screw the rim nut (1) gently against the rim with the tips of your fingers.

7.4.2 Brake system



Crash caused by brake failure

Worn brake discs and brake linings, as well as a lack of hydraulic fluid in the brake cable, reduce the braking power. This may cause a crash with injuries.

- ▶ Check the brake disc, brake linings and hydraulic brake system on a regular basis. Contact your specialist dealer if any of these components are worn.

The maintenance interval for the brake depends on the weather conditions and how frequent the

- ▶ Push brake lever and hold several times.
- ⇒ If you are unable to clearly detect the pressure point and it changes, the brake needs to be vented. Contact your specialist dealer.
- ▶ Check that the brake disc is no less than 1.8 mm at any point.
- ⇒ The brake discs have not reached their wear limit yet; brake discs need to be replaced if they have. Contact your specialist dealer.
- ▶ Check all visible electrical cables and cables for damage. If the sheathing is compressed, a brake is defective or a light does not work, the bicycle must be removed from service until the lines or cables have been repaired. Contact your specialist dealer.

7.4.7 Gear shift

- ▶ Check the gear shift and the *shifter* or the *twist grip* setting and adjust it as necessary.

7.4.8 Stem

- ▶ The stem and quick release system must be inspected at regular intervals. The specialist dealer should adjust them if necessary.
- ▶ If the hexagon socket head screw is also loosened, the headset backlash also needs to be adjusted. Medium-strength thread locker, such as Loctite blue, then needs to be applied to the loosened screws and the screws tightened as per specifications.
- ▶ Contact your specialist dealer if there is any wear or signs of corrosion.

bicycle is used. If the bicycle is used under extreme conditions such as rain, dirt or high mileage, maintenance must be performed more frequently.

7.4.3 Checking the brake linings for wear

Check brake linings after brake has been fully applied 1,000 times.

- 1 Check that the brake linings are no less than 1.8 mm wide at any point and no less than 2.5 mm between the brake lining and supporting plate.
 - 2 Push brake lever and hold. In doing so, check the transport safety wear gauge can fit between the brake lining supporting plates.
- ⇒ The brake linings have not reached their wear limit. Contact your specialist dealer if any of these components are worn.

7.4.4 Checking the pressure point

7.4.5 Checking the brake discs for wear

7.4.6 Electrical cables and brake cables

7.4.9 Checking the belt and chain tension

Notice

Excessive chain tension increases wear.

If the chain tension is too low, there is a risk that the *chain* or the *drive belt* will slip off the *chain wheels*.

► Check the chain tension once a month.

- 1 Check the chain tension in three or four positions, turning the crank a full revolution.

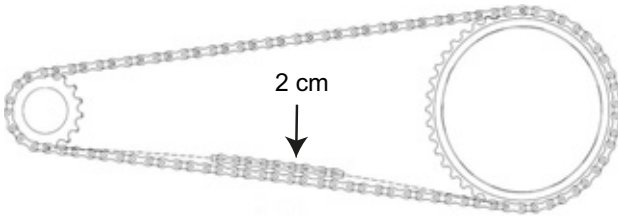

Figure 65: Checking the chain tension

- 2 If the *chain* can be pushed more than 2 cm, the *chain* or *drive belt* will need to be tensioned again by the specialist dealer.
 - 3 If the *chain* or the *drive belt* can only be pushed up and down less than 1 cm, you will need to slacken the *chain* or the *drive belt*.
- ⇒ The optimum chain tension is achieved if the *chain* or the *drive belt* can be pushed a maximum of 2 cm in the middle between the pinion and the toothed wheel. The crank must also turn without resistance.
- 4 If a hub gear is featured, the rear wheel must be pushed backwards or forwards to tighten the chain. Contact your specialist dealer.
 - 5 Check the handlebar grip is firmly in position.



8 Maintenance

WARNING

Injury due to damaged brakes

Special tools and specialist knowledge are required to repair the brakes. Incorrect or unauthorised assembly can damage the brakes. This may lead to an accident with injuries.

- ▶ Only specialist dealers may carry out repairs on brakes.
- ▶ Only carry out work or changes, such as dismantling, sanding or painting, which are permitted and described in the brake operating instructions.

Injury to the eyes

Problems may arise if the settings are not made properly and you may sustain serious injuries as a result.

- ▶ Always wear safety glasses to protect your eyes when carrying out maintenance work such as replacing components.

CAUTION

Crash caused by material fatigue

If the service life of a component has expired, the component may suddenly fail. This may cause a crash with injuries.

- ▶ Have the specialist dealer carry out six-monthly basic cleaning of the bicycle, preferably at the same time as the required servicing work.

CAUTION

Hazard for the environment due to toxic substances

The brake system contains toxic and environmentally harmful oils and lubricants. Such fluids will contaminate if they enter the sewers or groundwater.

- ▶ Dispose of lubricants and oils left over after repairs in an environmentally responsible way in accordance with statutory regulations.

You must have the specialist dealer perform maintenance every six months as a minimum. This is the only way to ensure that bicycles remain safe and fully functional. No matter whether disc brakes need replacing, brakes venting or wheels changing, many maintenance tasks require technical expertise, special tools and special lubricants. The bicycle may become damaged if the stipulated maintenance intervals and procedures are not carried out. That is why only specialist dealers may carry out maintenance.

- ▶ The retailer will check the bicycle based on the maintenance table in the Section 10.2.
- ▶ The specialist dealer will inspect the bicycle for any signs of material fatigue during basic cleaning.
- ▶ The specialist dealer will dismantle and clean the entire suspension fork interior and exterior. They will clean and lubricate the dust seals and slide bushings, check the torques and adjust the fork to the rider's preferred position. They will also replace the sliding collar if the clearance is too great (more than 1 mm on the fork bridge).
- ▶ The specialist dealer will fully inspect the interior and exterior of the rear frame damper, overhaul the rear frame damper, replace all air seals on air forks, overhaul the air suspension, change the oil and replace the dust wipers.
- ▶ They will pay particular attention to rim and brake wear. The spokes are re-tightened in accordance with the findings.

8.1 Axle with quick release



CAUTION

Crash caused by unfastened quick release

A faulty or incorrectly installed quick release may become caught in the brake disc and block the wheel. This will cause a crash.

- ▶ Install the front wheel quick release lever on the opposite side to the brake disc.

Crash caused by faulty or incorrectly installed quick release

The brake disc becomes very hot during operation. Parts of the quick release may become damaged as a result. The quick release comes loose. This will cause a crash with injuries.

- ▶ The front wheel quick release lever and the brake disc must be situated on opposite sides.

Crash caused by incorrectly set clamping force

Excessively high clamping force will damage the quick release and cause it to lose its function.

Insufficient clamping force will cause a detrimental transmission of force. The suspension fork or the frame may break. This will cause a crash with injuries.

- ▶ Never fasten a quick release using a tool (e.g. hammer or pliers).

Only use the clamping lever with the specified set clamping force.

8.1.1 Checking the quick release

- ▶ Check the position and clamping force of the quick release lever. The quick release lever must be flush with the lower housing. You must be able to see a slight impression on the palm of your hand when you close the quick release lever.



Figure 66: Adjusting the quick release clamping force

- ▶ Use a 4 mm hexagon socket spanner to adjust the clamping lever clamping force if required. Afterwards, check the quick release lever position and clamping force.

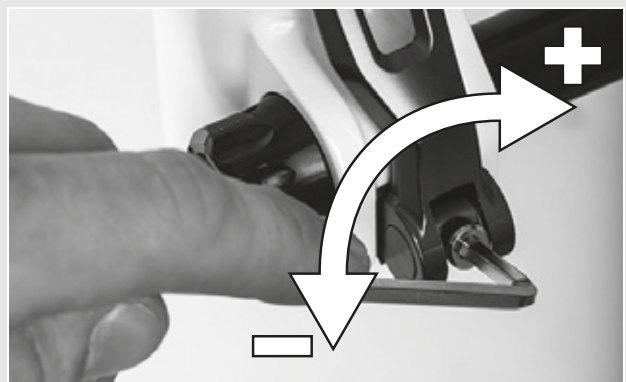

Figure 67: Adjusting the quick release clamping force

8.2 Adjusting the gear shift

If you cannot select the gears effortlessly, you will need to adjust the setting for the shift cable tension.

- ▶ Carefully pull the *adjusting sleeve* away from the shifter housing, turning it as you do so.
- ▶ Check the gear shift function after each adjustment.

8.2.1 Cable-operated gear shift, single-cable

Only applies to bicycles with this equipment

- ▶ For a smooth gear shift, adjust the adjusting sleeves on the shifter housing.



Figure 68: Adjusting sleeve (1) for the single-cable, cable-operated gear shift with shifter housing (2), example

8.2.2 Cable-operated gear shift, dual-cable

Only applies to bicycles with this equipment

- ▶ For a smooth gear shift, set the adjusting sleeves underneath the chain stay on the frame.
- ▶ The shift cable has around 1 mm play when it is pulled out gently.

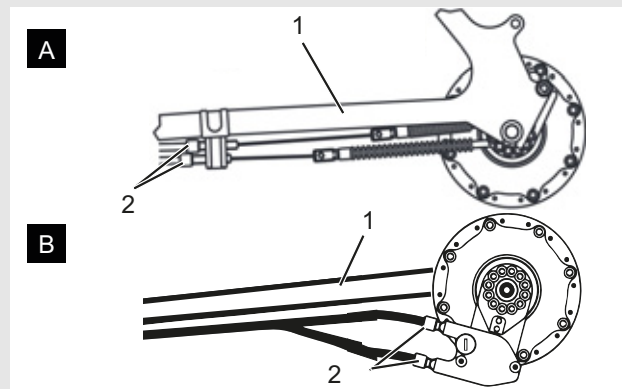

Figure 69: Adjusting sleeves (2) on two alternative versions (A and B) of a dual-cable, cable-operated gear shift on the chain stay (1)

8.2.3 Cable-operated twist grip, dual-cable

Only applies to bicycles with this equipment

- ▶ For a smooth gear shift, set the adjusting sleeves on the shifter housing.
- ⇒ There is noticeable play of around 2–5 mm (1/2 gear) when twisting the twist grip.

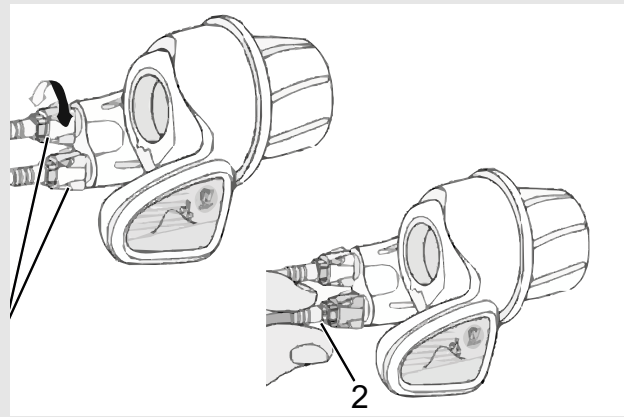

Figure 70: Twist grip with adjusting sleeves (1) and play of the gear shift (2)

9 Troubleshooting, fault clearance and repair

9.1 Repair

Special knowledge and tools are required for many repairs. That is why only a specialist dealer may perform repairs such as:

- Replacing tyres and rims
- Replacing brake pads and brake linings
- Replacing and tensioning the chain.

ensure that there is sufficient clearance for the tyre.

9.1.1 Original parts and lubricants

The individual parts of bicycles have been selected carefully and match to one another.

Only original parts and lubricants must be used for maintenance and repair.

The constantly updated accessory approval and parts list are Section 11, Documents and Drawings.

Observe the operating instructions for the new components.

9.1.2 Replacing the lighting

- ▶ Only use components of the respective power class for replacement.

9.1.3 Adjusting the headlight

- ▶ The *headlight* must be positioned, so that its light beam meets the road 10 m in front of the bicycle.

9.1.4 Tyre clearance check

The tyre needs to be checked each time a suspension fork tyre is changed to another size.

- 1 Release pressure from the fork.
- 2 Press fork together fully.
- 3 Measure the gap between the top of the tyre and the crown's lower surface. The gap must not be less than 10 mm. If the tyre is too large, the tyre will touch the crown's lower surface if the fork is fully pressed together.
- 4 Release pressure on fork and pump it up again if it is an air suspension fork.
- 5 Take into account the fact that the gap will be smaller if there is a guard. Check again to

10 Recycling and disposal

The bicycle is recyclable material. You must dispose of it and recycle it separately from the domestic waste in compliance with applicable

statutory regulations. Separate collection and recycling saves raw materials and ensures that all the regulations for protection of health and the environment are met when recycling the product.

- ▶ Never dismantle the bicycle for disposal purposes.
- ▶ You can return the bicycle to any specialist dealer free of charge. Depending on the region, further disposal options may be available.
- ▶ Store the individual parts of the decommissioned bicycle in a dry place and free from frost, where they are protected from direct sunlight.

10.1 Assembly report

Date:

Frame number:

Components	Description		Criteria		Measures if rejected
	Assembly/inspection	Tests	Acceptance	Rejection	
Front wheel	Assembly		O.K.	Loose	Adjust quick release
Kickstand	Check mount fastening	Functional check	O.K.	Loose	Retighten screws
Tyres		Tyre pressure check	O.K.	Tyre pressure too low/too high	Adjust tyre pressure
Frame	Check for damage – fracture, scratches		O.K.	Damage detected	<i>Take out of operation, new frame</i>
Handles, coverings	Check mount fastening		O.K.	Not provided	Retighten screws, new handles or coverings as specified in parts list
Handlebars, stem	Check mount fastening		O.K.	Loose	Retighten screws; new stem as specified in parts list if necessary
Steering headset	Check for damage	Functional check	O.K.	Loose	Retighten screws
Saddle	Check mount fastening		O.K.	Loose	Retighten screws
Seat post	Check mount fastening		O.K.	Loose	Retighten screws
Protective plate	Check mount fastening		O.K.	Loose	Retighten screws
Pannier rack	Check mount fastening		O.K.	Loose	Retighten screws
Attachments	Check mount fastening		O.K.	Loose	Retighten screws
Bell		Functional check	O.K.	No ring, too quiet, missing	New bell as specified in the parts list
Suspension elements					
Fork, suspension fork	Check for damage		O.K.	Damage detected	New fork as specified in the parts list
Rear frame damper	Check for damage		O.K.	Damage detected	New fork as specified in the parts list
Suspension seat post	Check for damage		O.K.	Damage detected	New fork as specified in the parts list
Brake system					
Brake lever	Check mount fastening		O.K.	Loose	Retighten screws
Brake fluid	Check fluid level		O.K.	Too little	Refill with brake fluid; new brake hoses if damaged
Brake linings	Check brake linings, brake discs or rims for damage		O.K.	Damage detected	New brake linings, brake discs or rims
Back-pedal brake braking armature	Check mount fastening		O.K.	Loose	Retighten screws
Light system					
Dynamo/battery	First examination		O.K.	Fault	<i>Taking out of service, new battery or dynamo</i>
Light cabling	Connections, correct wiring		O.K.	Cable defective, no light	New cabling
Rear light	Side light	Functional check	O.K.	No constant light	<i>Take out of service; new rear light as specified in parts list; replace if necessary</i>
Front light	Side light, daytime riding light	Functional check	O.K.	No constant light	<i>Take out of service; new front light as specified in parts list; replace if necessary</i>
Reflectors	All complete, state, fastening		O.K.	Damaged or not all complete	New reflectors
Drive/gear shift					
Chain/cassette/pinion/chainring	Check for damage		O.K.	Damage	Refasten if necessary or replace as specified in parts list

Components	Description		Criteria	Measures if rejected	
Chain guard/spoke guard	Check for damage		O.K.	Damage	Replace as specified in parts list
Bottom bracket axle/crank	Check mount fastening		O.K.	Loose	Retighten screws
Pedals	Check mount fastening		O.K.	Loose	Retighten screws
Shifter	Check mount fastening	Functional check	O.K.	Loose	Retighten screws
Shift cables	Check for damage	Functional check	O.K.	Loose or defective	Adjust shift cables; new shift cables if necessary
Front derailleur	Check for damage	Functional check	O.K.	Gear shift difficult or not possible	Adjust
Rear derailleur	Check for damage	Functional check	O.K.	Gear shift difficult or not possible	Adjust

Technical check, test ride

Components	Description		Criteria		Measures if rejected
	Assembly/inspection	Tests	Acceptance	Rejection	
Brake system		Functional check	O.K.	No full braking; braking distance too long	Locate defective part in brake system and correct
Gear shift under operating load		Functional check	O.K.	Problems when shifting gear	Readjust gear shift
Suspension components (fork, shock absorber, seat post)		Functional check	O.K.	Suspension too deep or no longer exists	Locate defective component and correct
Light system		Functional check	O.K.	No continuous light, too bright	Locate defective part in light system and correct
Test ride			No strange noises	Strange noises	Locate source of noise and correct

Date	
Fitter's name:	
Final inspection by workshop manager	

10.2 Maintenance instructions

Diagnosis and documentation of current status

Date:

Frame number:

Components	Frequency	Description			Criteria		Measures if rejected
		Inspection	Tests	Maintenance	Acceptance	Rejection	
Front wheel	6 months	Assembly			O.K.	Loose	Adjust quick release
Kickstand	6 months	Check mount fastening	Functional check		O.K.	Loose	Retighten screws
Tyres	6 months		Tyre pressure check		O.K.	Tyre pressure too low/too high	Adjust tyre pressure
Frame	6 months	Check for damage – fracture, scratches			O.K.	Damage detected	Take bicycle out of service, new frame
Handles, coverings	6 months	Wear; check if fastened securely			O.K.	Not provided	Retighten screws, new handles or coverings as specified in parts list
Handlebars, stem	6 months	Check mount fastening			O.K.	Loose	Retighten screws; new stem as specified in parts list if necessary
Steering head-set	6 months	Check for damage	Functional check	Lubricating and adjustment	O.K.	Loose	Retighten screws
Saddle	6 months	Check mount fastening			O.K.	Loose	Retighten screws
Seat post	6 months	Check mount fastening			O.K.	Loose	Retighten screws
Protective plate	6 months	Check mount fastening			O.K.	Loose	Retighten screws
Pannier rack	6 months	Check mount fastening			O.K.	Loose	Retighten screws
Attachments	6 months	Check mount fastening			O.K.	Loose	Retighten screws
Bell	6 months		Functional check		O.K.	No ring, too quiet, missing	New bell as specified in the parts list
Suspension elements							
Fork, suspension fork	To manufacturer's specifications	Check for damage – corrosion, fracture		Maintenance as specified by manufacturer Lubrication, oil change as specified by manufacturer	O.K.	Damage detected	New fork as specified in the parts list
Rear frame damper	To manufacturer's specifications	Check for damage – corrosion, fracture		Maintenance as specified by manufacturer Lubrication, oil change as specified by manufacturer	O.K.	Damage detected	New fork as specified in the parts list
Suspension seat post	To manufacturer's specifications	Check for damage		Maintenance as specified by manufacturer	O.K.	Damage detected	New fork as specified in the parts list
Brake system							
Brake lever	6 months	Check mount fastening			O.K.	Loose	Retighten screws
Brake fluid	6 months	Check fluid level		Depending on time of year	O.K.	Too little	Top up brake fluid; <i>take bicycle out the out of service</i> if damaged; new brake hoses
Brake linings	6 months	Check brake linings, brake discs or rims for damage			O.K.	Damage detected	New brake linings, brake discs or rims
Back-pedal brake braking armature	6 months	Check mount fastening			O.K.	Loose	Retighten screws
Brake system	6 months	Check mount fastening		Functional check	O.K.	Loose	Retighten screws

Components	Frequency	Description			Criteria		Measures if rejected
		Inspection	Tests	Maintenance	Acceptance	Rejection	
Light system							
Dynamo	6 months	First examination			O.K.	Error message	Contact battery manufacturer; <i>take out of service</i> , new battery
Light cabling	6 months	Connections, correct wiring			O.K.	Cable defective, no light	New cabling
Rear light	6 months	Side light	Functional check		O.K.	No constant light	New rear light as specified in parts list; replace if necessary
Front light	6 months	Side light, daytime riding light	Functional check		O.K.	No constant light	New front light as specified in parts list; replace if necessary
Reflectors	6 months	All complete, state, fastening			O.K.	Damaged or not all complete	New reflectors
Drive/gear shift							
Chain/cassette/pinion/chainring	6 months	Check for damage			O.K.	Damage	Refasten if necessary or replace as specified in parts list
Chain guard/spoke guard	6 months	Check for damage			O.K.	Damage	Replace as specified in parts list
Bottom bracket axle/crank	6 months	Check mount fastening			O.K.	Loose	Retighten screws
Pedals	6 months	Check mount fastening			O.K.	Loose	Retighten screws
Shifter	6 months	Check mount fastening	Functional check		O.K.	Loose	Retighten screws
Shift cables	6 months	Check for damage	Functional check		O.K.	Loose or defective	Adjust shift cables; new shift cables if necessary
Front derailleur	6 months	Check for damage	Functional check		O.K.	Gear shift difficult or not possible	Adjust
Rear derailleur	6 months	Check for damage	Functional check		O.K.	Gear shift difficult or not possible	Adjust

Technical inspection, checking safety, test ride

Components	Description		Criteria		Measures if rejected
	Assembly/inspection	Tests	Acceptance	Rejection	
Brake system		Functional check	O.K.	No full braking; braking distance too long	Locate defective part in brake system and correct
Gear shift under operating load		Functional check	O.K.	Problems when shifting gear	Readjust gear shift
Suspension components (fork, shock absorber, seat post)		Functional check	O.K.	Suspension too deep or no longer exists	Locate defective component and correct
Light system		Functional check	O.K.	No continuous light, too bright	Locate defective part in light system and correct
Test ride			No strange noises	Strange noises	Locate source of noise and correct

Date	
Fitter's name:	
Final inspection by workshop manager	

11 Glossary

Bicycle for young adults

Source: ISO 4210-2: bicycle designed for use on public roads by a young adult whose weight is less than 40 kg, with maximum saddle height of 635 mm or more and less than 750 mm (see ISO 4210).

Brake lever

Source: EN 15194:2017: lever used to apply the brake.

Braking distance

Source: EN 15194:2017: distance that a bicycle travels from when braking commences until the bicycle reaches the point where it comes to rest.

Cargo bike

Source: DIN 79010: bicycle mainly designed to carry goods.

CE marking

Source: Directive on Machinery: the manufacturer uses the CE marking to declare that the bicycle complies with the applicable requirements.

City and trekking bicycles

Source: ISO 4210-2: bicycle designed for use on public roads primarily for means of transportation or leisure.

Consumables

Source: EN 82079-1: any part or material that is needed to continue using or maintain the product.

Decommissioning

Source: DIN 31051: intentional, unlimited interruption in an object's functional capability.

Disc brake

Source: EN 15194:2017: brake in which brake pads are used to grip the lateral faces of a thin disc attached to or incorporated into the wheel hub.

Drive belt

Source: EN 15194:2017: seamless ring belt which is used as a means of transmitting drive force.

Electrical control system

Source: EN 15194:2017: electronic and/or electrical component or an assembly of components provided for installation into a vehicle, together with all electrical connections and associated wiring for the motor electrical power assistance.

Electrically power assisted cycle, bicycle

Source: EN 15194:2017: electrically power assisted cycle, equipped with pedals and an auxiliary electric motor, which cannot be propelled exclusively by means of the auxiliary electric motor, except in start-up assistance mode.

Emergency stop

Source: ISO 13850:2015, Function or signal, designed: — to avert arising or reduce existing hazards to persons, damage to machinery or to work in progress; – to be initiated by a single human action.

Fault

Source: EN 13306:2018-02, 6.1: state of an item (4.2.1) characterized by its inability to perform a required function (4.5.1), excluding such inability during preventive maintenance or other scheduled actions or due to lack of external resources.

Folding bicycle

Source: ISO 4210-2: bicycle designed to fold into a compact form, facilitating transport and storage.

Fork steerer

Source: EN 15194:2017: part of a fork that rotates around the steering axis of a bicycle frame head tube. It is normally connected to the fork crown or directly to the fork legs, and is normally the point of connection between the fork and the handlebar stem.

Fracture

Source: EN 15194:2017: unintentional separation into two or more parts.

Maintenance

Source: DIN 31051: maintenance is generally performed at regular intervals and often carried out by trained technical staff. This ensures a maximum service life and low wear and tear for the maintained items. Proper maintenance is often also a pre-requisite for providing a warranty.

Maximum continuous power

Source: ZEG: the maximum continuous power is the maximum power for the electric motor output shaft during 30 minutes.

Maximum saddle height

Source: EN 15194:2017: vertical distance from the ground to the point where the top of the seat surface is intersected by the seat-post axis, measured with the saddle in a horizontal position and with the seat-post set to the minimum insertion-depth mark.

Maximum tyre pressure

Source: EN 15194:2017: maximum tyre pressure recommended by the tyre or rim manufacturer for a safe and efficient performance. If the rim and tyre both indicate a maximum tyre pressure, the maximum inflation pressure is the lower of the two pressures indicated.

Minimum insertion depth mark

Source: EN 15194:2017: mark indicating the minimum insertion depth of handlebar stem into fork steerer (fork stem) or seat post into frame.

Model year

Source: ZEG: the model year refers to the first production year that the series-manufactured bicycle was manufactured in the version in question and is not always identical to the year of manufacture. The year of manufacture may be before the model year in some cases. If no technical modifications are made to the series, bicycles from a previous model year may also be produced after the model year in question.

Mountain bike

Source: ISO 4210-2: bicycle designed for use off-road on rough terrain, on public roads, and on public pathways, equipped with a suitably strengthened frame and other components, and, typically, with wide-section tyres with coarse tread patterns and a wide range of transmission gears.

Negative deflection

Negative deflection or sag is fork compression caused by the weight of the rider and their gear (e.g. a backpack), their sitting position and the frame geometry.

Off-road rough terrain

Source: EN 15194:2017: rough gravel tracks, forest trails and other generally off-road tracks where tree roots and rocks are likely to be encountered.

Operating instructions

Source: ISO/DIS 20607:2018: part of the user information that machine manufacturers provide to machine operators; it contains guidance, instructions and tips related to the use of the machine in all its life cycle phases.

Permitted total weight

Source: EN 15194:2017: weight of the fully assembled bicycle plus the rider and baggage, as specified by the manufacturer.

Pressure point

Source: ZEG: The pressure point on a brake is the point on the brake lever where the brake disc or brake pads respond and the braking process is initiated.

Quick-release device, quick release

Source: EN 15194:2017: lever actuated mechanism that connects, retains or secures a wheel or any other component.

Racing bicycle

Source: ISO 4210-2: bicycle designed for amateur rides at high speed and for use on public roads having a control and steering assembly with multiple grip positions to provide an aerodynamic posture, a multi-speed transmission system and a tyre width not greater than 28 mm with the fully assembled bicycle having a maximum mass of 12 kg.

Rebound

The rebound defines the speed at which the fork rebounds after being loaded.

Rechargeable battery

Source: DIN 40729:1985-05: a rechargeable battery is an energy storage device that can store supplied electrical energy as chemical energy (charging) and release it as electrical energy when required (discharging).

Seat post

Source: EN 15194:2017: component that clamps the saddle (with a bolt or assembly) and connects it with the frame.

Serial number

Source: ZEG: each bicycle has an eight-digit type number which is used to specify the design model year, the type and the version.

Shut-off speed

Source: EN 15194:2017: speed reached by the bicycle at the moment the current has dropped to zero or to the no load current value.

Slippage

Source: DIN 75204-1:1992-05: the difference in relation to vehicle speed between the vehicle speed and the speed of its wheels at their circumference.

Spare part

Source: EN 13306:2018-02, 3.5: item intended to replace a corresponding item in order to retain or maintain the original required function of the item.

Suspension fork

Source: EN 15194:2017: front wheel fork incorporating controlled, axial flexibility to reduce the transmission of road-shocks to the rider.

Suspension frame

Source: EN 15194:2017: frame incorporating controlled, vertical flexibility to reduce the transmission of road-shocks to the rider.

Total deflection

Source: Benny Wilbers, Werner Koch: Neue Fahrwerkstechnik im Detail (New chassis technology in detail): The distance that the wheel travels between an unloaded and a loaded position is called total deflection. When at rest, the vehicle's mass is applied to the springs and reduces the total deflection by the *negative deflection* to the positive deflection.

Wear

Source: DIN 31051: reduction in useful life (4.3.4), caused by chemical and/or physical processes.

Weight of ready-to-ride bicycle

Source: ZEG: the indicated weight for a ready-to-ride bicycle refers to the weight of a bicycle at the time of sale. The weight of each additional accessory must be added to this weight.

Wheel

Source: EN 15194:2017: assembly or combination of hub, rim and spokes or disc, but excluding tyre assembly.

Work environment

Source: ISO 9000:2015: set of conditions under which work is performed.

Year of manufacture

Source: ZEG: the year of manufacture is the year when the bicycle was manufactured. The production period is always from August to July of the following year.

12 Keyword index

A

- Air chamber, 13
- Air valve,
 - Fork, 11
 - Rear frame damper, 13

B

- Back-pedal brake,
 - braking, 62
- Battery,
 - disposing of, 86
- Belt tension, 79
- Brake arm, 13
- Brake calliper, 14
- Brake disc, 14
- Brake lever, 21
 - adjusting the pressure point, 45
- Brake lining, 13
 - maintaining, 78

C

- Chain guard,
 - checking, 57, 58
- Chain tension, 79
- Chain, 8
 - maintaining, 79
- Charger,
 - disposing of, 86
- Clamping force,
 - Checking the quick releases, 26
 - Setting the quick releases, 26
- Control panel 21

D

Display 21

F

- Fork, 9
 - setting the compression damper, 69
 - Fork end, 9
 - Setting the rebound damper, 68
- Frame, 8
- Front wheel brake, 13, 14, 15
 - braking, 62
- Front wheel, see Wheel

G

- Gear shift twist grip,
 - checking, 78
- Gear shift,
 - maintaining, 78
 - switching, 69

H

- Handlebars, 8, 21
- Headlight, 21
- Hub, 9

I

Initial commissioning, 23

L

Lever, 13

M

- Minimum insertion depth marking, 37
- Mudguards,
 - checking, 57, 58

O

- On-screen indicator, 56
- O-ring, 13

P

- Packaging, 23
- Pannier rack, 8
 - changing, 60
 - checking, 57, 58
 - using, 59
- Pedal, 15
- Position, 21

Q

Quick release, 9

R

- Rear frame damper,
 - structure, 12, 13
- Rear wheel brake, 14, 15
- Riding light,
 - checking function, 57, 58
- Rim brake locking lever 14
- Rim, 9
 - checking, 76
- Roller brake,
 - braking, 62

S

- Saddle, 8
 - changing the saddle tilt, 35
 - changing the seat length, 39
 - determining the saddle height, 35, 39
- Seat post, 8
- Setting wheel, 13
- Shifter,
 - checking, 78
 - setting, 83
- Spoke, 9
- Stem,
 - checking,
 - Handlebars,
 - checking, 32
- Suspension head, 9

T

- Transportation, 22
- Transporting, see Transportation
- Tyres, 9
 - checking, 76

U

Using 70

V

- Valve, 9
 - Dunlop valve, 9
 - Presta valve, 9
 - Schrader valve, 9

W

- Wheel,
 - installing, 24, 25, 26, 29, 30, 31, 32
 - maintaining, 76